

# THE SPORTPLANE BUILDER

BY TONY BINGELIS, 8509 GREENFLINT LANE, AUSTIN, TEXAS 78759

## INSTRUMENT PANEL PREPARATION

**"S**HOULD I INSTALL a well equipped gyro instrumented panel or should I try to keep it light, simple and inexpensive?" Resolve that question and you will be able to move on to other less monumental decisions that will have to be made before you can install your instrument panel. These other questions, for example, will undoubtedly be:

What can I use for my instrument panel? How should I arrange the instruments? Where can I put my compass, the ignition switch, switches and circuit breakers . . . maybe I should install fuses instead of circuit breakers? How many switches and circuit breakers or fuses will I need?

It seems that one question leads to another but in the end I am sure you will have considered all the important details.

### First, A Cardboard Layout

As an aid in resolving the many questions you raise, you should make an accurate full-sized cardboard template of your proposed instrument panel. Check it against the aircraft structure to be sure it fits. Next, with a compass, make some dummy instruments by drawing as many  $3\frac{1}{8}$ " and  $2\frac{1}{4}$ " shapes as you expect to use (do the same for your switches and circuit breakers using  $\frac{1}{2}$ " circles). Label each cardboard pattern and then cut them all out. Now you are all set to enjoy an hour or two shuffling the cardboard instrument cutouts around on the cardboard dummy panel.

**NOTE:** Instruments must not be spaced so close that they touch. Although you can achieve a minimum spacing of  $\frac{1}{8}$ " between instruments I believe a  $\frac{1}{4}$ " spacing will produce a better, more rigid instrument panel. This means that your instruments should be spaced on  $3\frac{1}{2}$ " centers. See Figure 1.

After you are satisfied with your arrangement, tape each cardboard instrument to the dummy panel with bits of masking tape. Stand back and take a critical look at the resulting arrangement. Be sure that the most referenced instruments will be easy to read and that their cases will clear the framework behind the panel. Be sure, too, that the ignition switch (it requires a  $\frac{7}{8}$ " diameter mounting hole) has sufficient area behind the panel so that its connections can be readily made.

If you intend to hinge the instrument panel along the bottom to provide easy access to behind the panel, be sure that the longer instruments will clear the upper frame as the hinged panel is tilted open. Do you have the switches and circuit breakers grouped conveniently where you can reach them? Maybe you will have to locate them on a sub panel somewhere else. Now is the time to finalize the layout.

In making a simple sparsely equipped instrument panel you can trace the cardboard patterns directly onto your real, metal or plywood, instrument panel blank. If, on the other hand, your instrument panel is for an

airplane that will have many instruments and accessories, I would recommend that you use the cardboard mock-up only as a guide and make your actual layout directly on the metal bank using a fine point felt pen (Sharpie or similar), a pair of dividers, a square and a good straight edge. This should guarantee that all the instruments, switches, etc., will be perfectly spaced and aligned.

### The Instrument Panel

Conventional instrument panels, for the most part, are cut out of .063" aluminum sheet. Some builders prefer to make theirs of .080" or  $\frac{1}{8}$ " plate. No reason for this heavier material except, possibly, for larger IFR panels that will be loaded with heavy gauges and equipment. In a similar vein, there is no valid reason to insist on using 2024 T3 for your panel unless you already just happen to have a piece large enough . . . 6061 T6 is more readily available and is considerably less costly.

Not all instrument panels are made of aluminum. Some builders have made and installed plywood panels in VFR aircraft and managed to achieve most pleasing effects.

Currently, the many composite aircraft, in an attempt to keep weight at a minimum, feature structural instrument panels. That is, the instrument openings are cut directly into a strategically located bulkhead. The rather thick bulkhead ( $\frac{1}{4}$ " to  $\frac{3}{8}$ ") provides an interesting display for the recessed instruments.



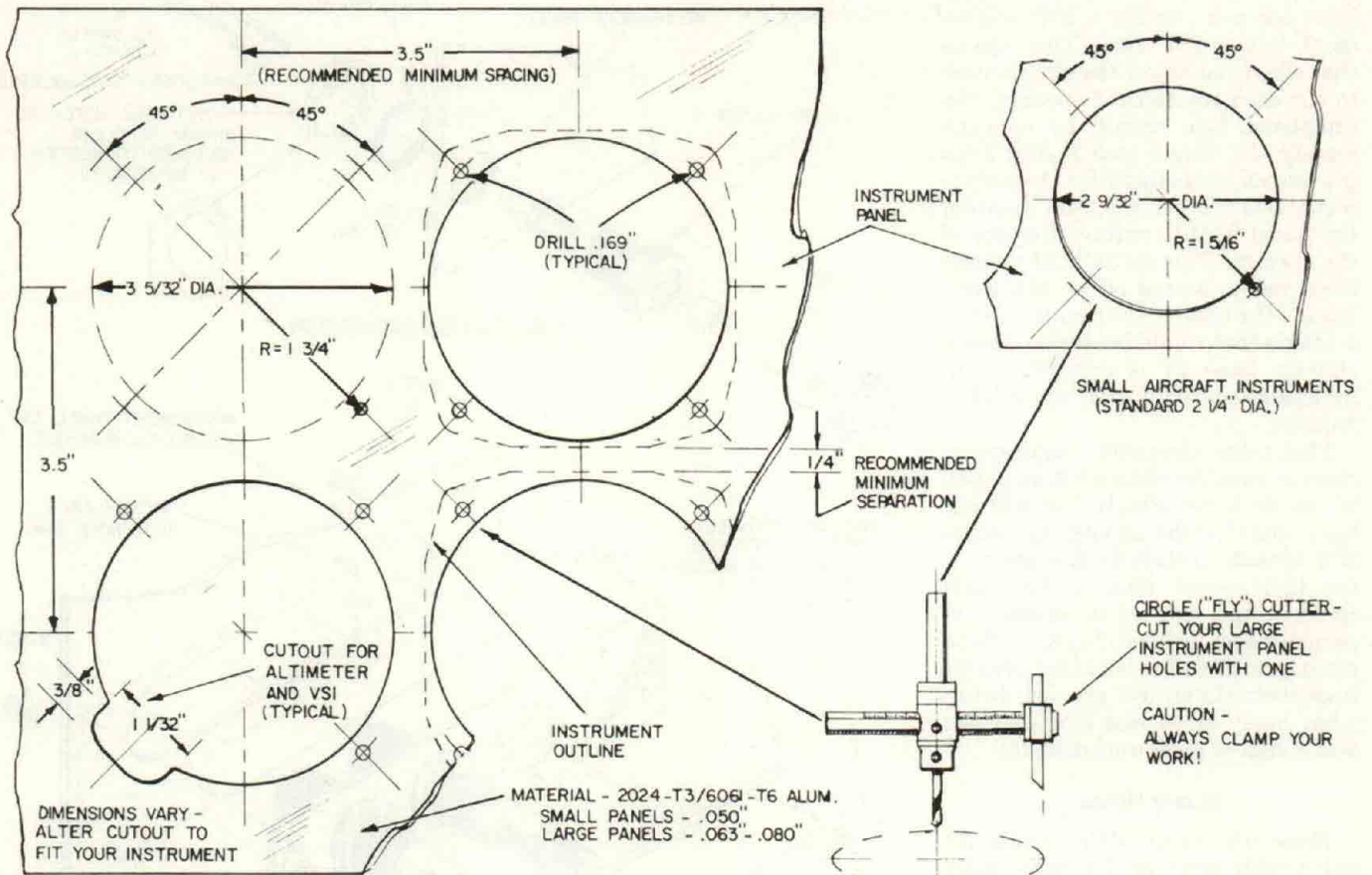

STANDARD 3 1/8" AIRCRAFT INSTRUMENTS

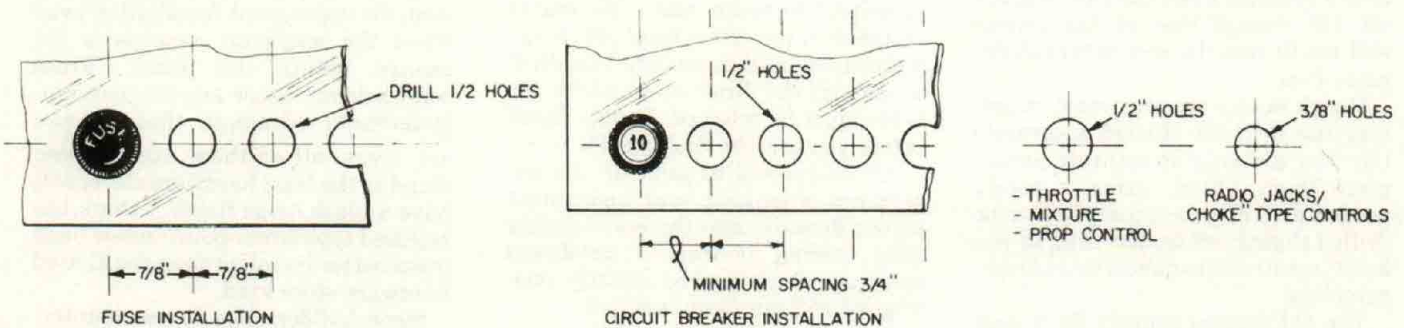
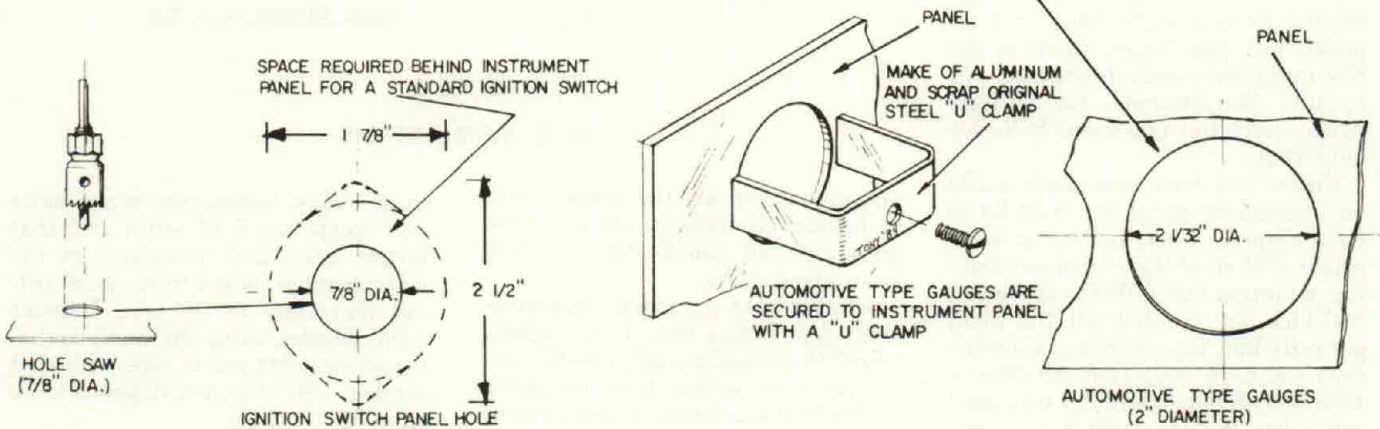

FIGURE I.

INSTRUMENT PANEL LAYOUT DETAILS



Here's a profound observation. You can't get a  $3\frac{1}{8}$ " instrument into a  $3\frac{1}{8}$ " hole, nor can you get a  $2\frac{1}{4}$ " instrument into a  $2\frac{1}{4}$ " hole. This means that when you adjust the circle cutter to cut each instrument opening, the completed hole should be approximately  $\frac{1}{32}$ " larger (see Figure 1) to provide an easy slip fit for the instrument. Don't forget, too, that painting the panel further reduces the size of the opening. This extra build-up may force you to scrape off all the paint around the edge of the opening. What a shame that would be. Believe me, a slightly loose fit is completely unnoticeable and will save you a lot of anguish.

This same clearance requirement must be considered for a tilting panel. If you fit it too closely you will not have space for the upholstery (unless it is already installed). Reworking a too tight panel after it has been finished and painted is another experience best avoided. In short, these extra good close fits (and that goes for inspection plates, too) are not always what many of us had long believed was a sign of good workmanship.

### Screw Holes

These are tricky little rascals. To begin with, don't drill 4 screw holes for mounting each instrument. Although most instruments do require 4 mounting holes, some require only 2 or 3. So, unless you don't mind explaining unused screw holes in your panel, you had better check to see how many holes each instrument will require. For example, my vacuum gauge needs but two screw holes for mounting.

Unless you have previously made an instrument panel you may be in for a surprise when you try to accurately drill all of those innocent looking mounting holes. Well, maybe you will luck out and drill all 4 of them perfectly but, take it from me, by the time you have completed the 20th or 40th or 80th hole, there is a very good possibility that you will have somehow misdrilled a few that are slightly off. Off enough that all the screws will not fit into the instrument at the same time.

Punch marks are important in getting the drill bit started accurately but they are only as accurate as you place them. Often, using a poorly ground drill bit can cause a hole to be drilled slightly off center. And, as you know, small errors have a way of compounding.

The old fashion remedy for a non-conforming hole is to elongate it with a small rate tail (round) file. Occasionally a slightly off hole can be nullified by redrilling it with a slightly larger drill bit. After you install the

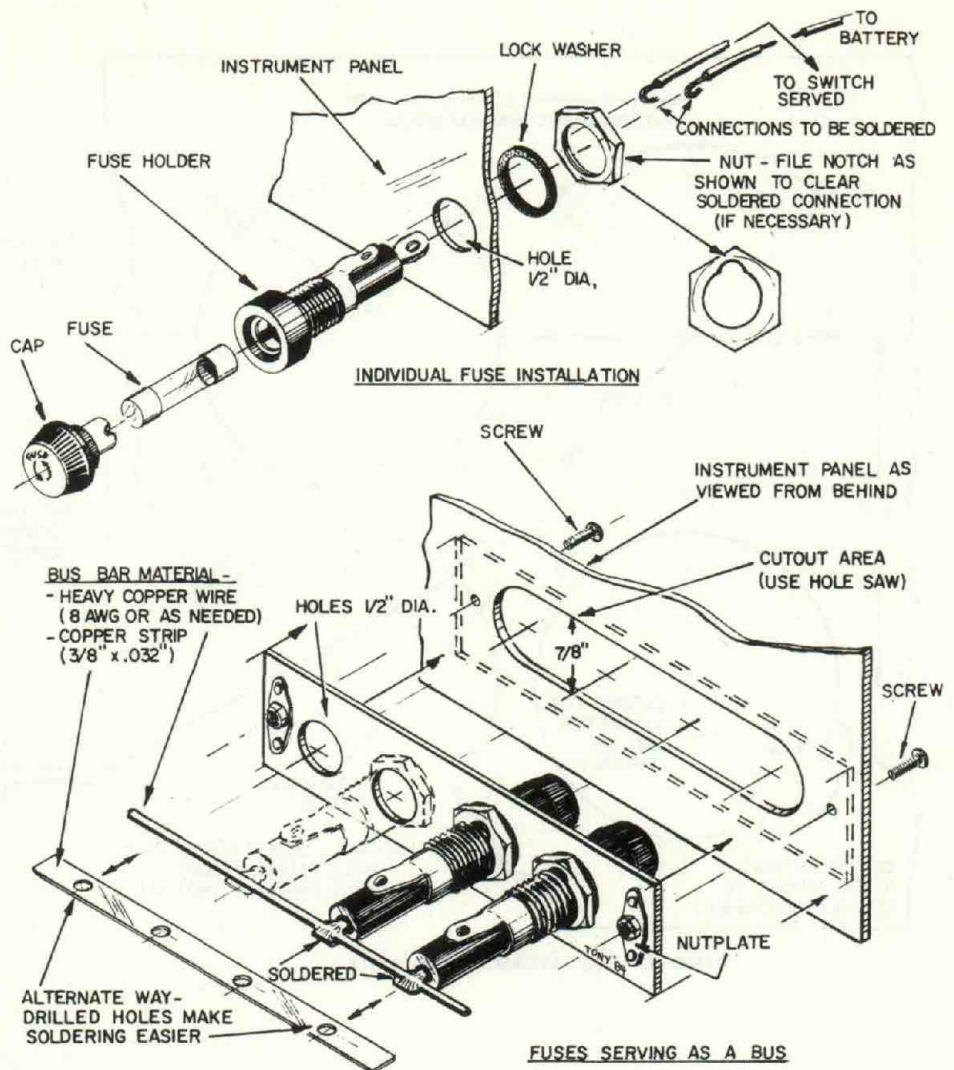

FIGURE 2.

### FUSE INSTALLATIONS

instrument screws, the screw heads will discretely hide any minor transgressions and nobody but you will know about them.

What if after you install an instrument you notice that it is slightly tilted? If it is bad enough to notice you had better try to level it by elongating each of the four holes in small increments and in the proper direction. It is helpful to make small ink marks adjacent to the screw head (while the instrument is temporarily installed) to identify the direction in which the holes must be relieved. Double check before you put the file to work.

All this serves to point up the importance of making your instrument layout directly onto the panel rather than tracing it from a cardboard mock-up which can be slightly misaligned without being noticed.

### Instrument Screws and Their Installation

You will find the 6-32 brass instrument screws the most convenient size

to use. Most instrument screw holes can accept an 8-32 screw but that larger screw isn't necessary as the instrument is locked in its panel cutout regardless of the size fastener used. Besides, using the small diameter screw helps you to cope with that random hole that just happens to be off a bit.

Brass screws are a standard use item for instrument installation even when the magnetic compass is not located within the panel. (Brass screws do not cause any magnetic interference.) Although these screws are brass, all of them except those found at the local hardware store, will have a black oxide finish. I think the recessed type (cross-point) screw head looks better installed than the slotted hardware store kind.

Some builders like to use countersunk screws. These too are available but unless your instrument panel is at least .063" (thick) countersinking the panel holes may result in making them oversized. Besides, it is very dif-



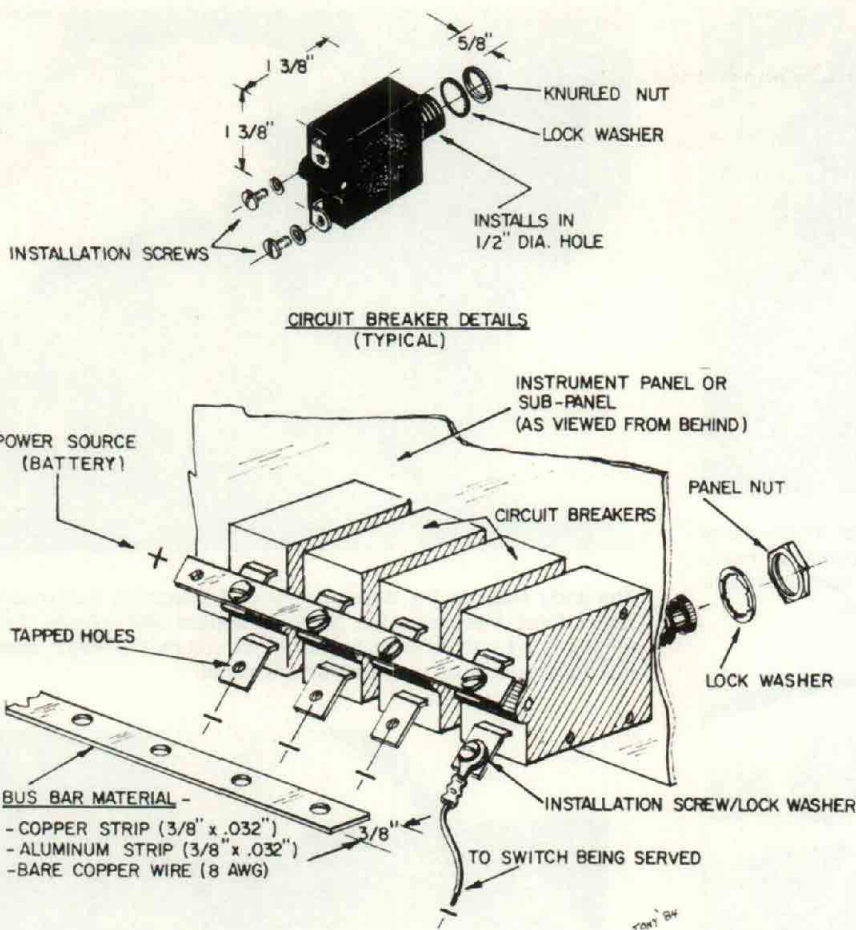

FIGURE 3.

### CIRCUIT BREAKERS SERVE AS A BUS BAR

difficult to countersink all 40 to 100 screw holes perfectly . . . and they are most unforgiving of a slightly elongated or misaligned hole whereas the round head screws cover for you nicely.

I find the 5/8" length instrument screw to be the most practical but, unfortunately, most places stock only the 1/2", 3/4" and 1" length instrument screws. Most of the time I find the 1/2" screws are a bit short and the others too long. As you know from experience, it is easier to cut off a long screw than it is to stretch one.

**NOTE:** Never use a screw longer than 5/8" in length when mounting a Directional Gyro. You may damage it. Go by the placarded screw length if one is attached.

Some instruments have built-in nuts and their installation is a distinct pleasure as you can do all the work from the front of the panel. Other instruments that have to have hand placed nuts and lock washers can be very difficult to install, especially in some of the most inaccessible locations imaginable behind the panel. Here is a possible fix for you gents with big hands.

### Modifying Instrument Mounting Holes

Modify the instrument mounting holes that do not have built in threaded inserts by making your own (this may not work on all instruments so check yours out).

First, install a 5/32 pop rivet. This will usually fit the mounting hole nicely. Use the "nail" from a 1/8" pop rivet when you get ready to set it in the instrument. (The 1/8" pop rivet nail causes the 5/32 rivet to swell, giving it a very snug fit in the instrument.)

Then take a 1/8" drill bit and ream the hole (after you have gently driven out the nail head). Finish the inserted pop rivet by tapping your own threads with a 6-32 tap. Do the thread tapping slowly and carefully, reversing the tap every half turn to clear the chips. Remember, the pop rivet is soft aluminum and tends to "gum" the tap. Don't hurry the process.

The end result should be most satisfying as you will now have 4 non-magnetic threaded inserts built into the instrument mounting holes.

Hold on now, amigos . . . don't go off and start "improving" on the

method by trying to do the same thing with Tric-Nuts (Registered) as those tougher threaded inserts can be expanded enough to break an instrument case mounting hole.

### Fuse Bus Bar

Fuses can be installed individually but then each would have to have one terminal connected to a power source (battery). All these separate wires do nothing but add complexity and weight to the installation. A better way is to group the fuses and solder a heavy copper wire across one terminal of each fuse creating a power bus (see Figure 2). Since most fuses require the use of soldered connections, their removal for any reason can be difficult, especially at the airport where no electricity is available for your soldering iron. To facilitate removal of the fuse bus for any reason you could fashion it as shown in Figure 2.

### Circuit Breaker Bus Bar

Circuit breakers, like fuses, are grouped in a row to create a convenient power bus by installing a copper or aluminum strip across one of the terminals of each circuit breaker. This arrangement reduces the number of wires you would otherwise have to install behind your instrument panel. As with the fuse installation, circuit breakers must have easy access to their back side. Unlike fuses, however, the bus bar need not be soldered to the circuit breakers as each terminal strip has a tapped hole and the bar can be secured with small screws.

There is a type of circuit breaker that is a combination switch and circuit breaker. It is a very desirable unit and is worth checking into. Instead of buying and installing a sepa-

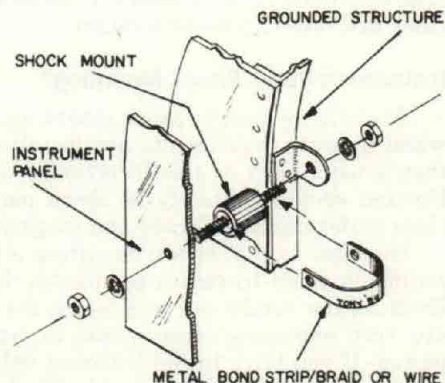
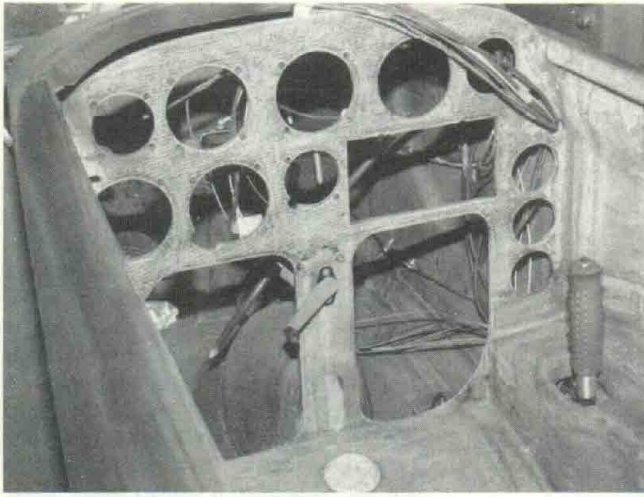

FIGURE 4.

### ELECTRICALLY GROUND SHOCK-MOUNTED INSTRUMENT PANELS





We rarely see a before and after example of an instrument panel so it is interesting to note that the structural bulkhead really doubles as an instrument panel. The instrument openings have been cut and the screw attachment holes drilled.

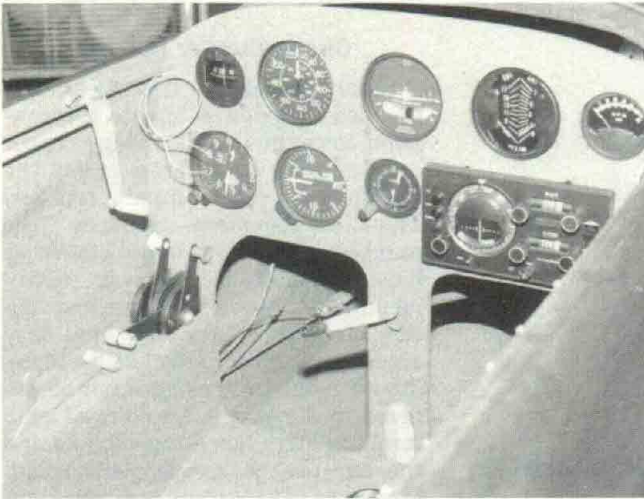

Here is the after shot. After the instruments have been installed and a little paint added, a remarkable transformation takes place.

rate switch and a separate circuit breaker, you may find it as economical to obtain some of those dual breaker units (they are very expensive though!).

### Instrument Panel Shock Mounting?

There is no need to shock mount an instrument panel when no gyro instruments are installed. However, gyro instruments such as the Directional Gyro and Artificial Horizon should definitely be shock mounted to improve their performance accuracy and longevity.

Needless to say, shock mounting a portion of the instrument panel increases complexity in its installation. Even so, the results are well worth the effort since these are very expensive instruments to replace or have repaired. If you have to shock mount only a single instrument, you might find it easier to shock mount at least a portion of the panel along with additional instruments than it is to just shock mount a single instrument.

One final note. Don't forget to ground a shock mounted panel as it could cause radio reception and other problems. Figure 4 shows how you can do this but you wood and composite builders be sure that your primary instrument panel is also grounded.

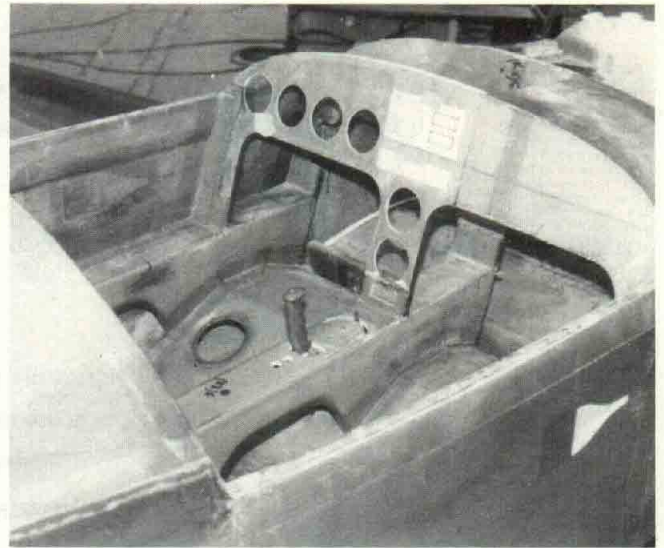

The early stage in the development of A Dragonfly instrument panel. First, there were the usual cardboard trial layouts. You simply don't drill random holes in a structural bulkhead, even if it does double as your instrument panel.

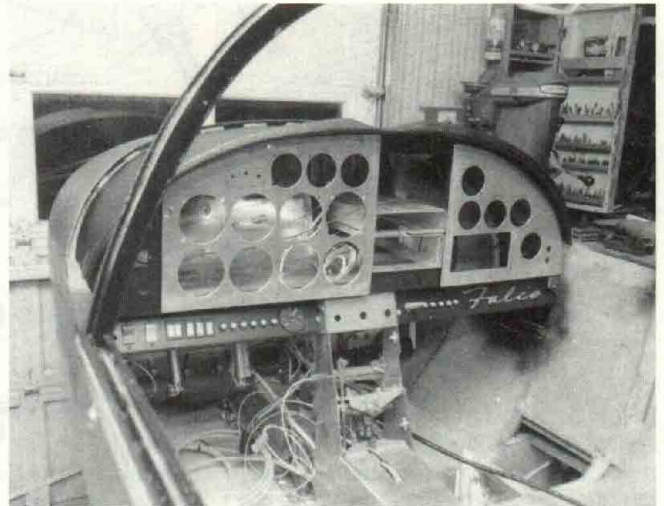

It is apparent that a large complex instrument panel requires considerable planning and careful layout to accommodate everything before any metal is cut. That's right, it's a Falco, but how did you guess?

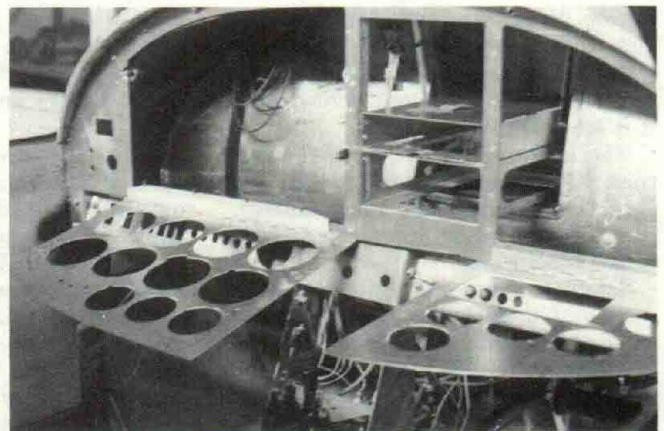

Access is great but if you use hinged panels better be sure your top row instruments will clear the frame. Be sure, too, to allow extra wiring lengths. Use of aluminum tubing plumbing is limited because it cannot flex when panel is opened.