

Custom Flight Trimming

My tips for in house use are pasted below from numerous emails and requests:

This presupposes that you have accomplished the Annex E properly, checked the engine and systems for safety etc.

Preflight Rules before you fly:

Rule 1. Check the incidence with a digital level at the root and the tip of each wing. Both root and tips should be within .1 degree. Some of the wing tips are off a little. If you have never built an incidence gauge, it is essentially a long ruler shaped as a C with V blocks on the two legs which when placed on the leading edge and trailing edge show the angle of the wing. Use two T squares clamped together and a couple wood blocks and route a dado in the block to hold it set. We are checking for twist and build errors here.

Incidence Meter

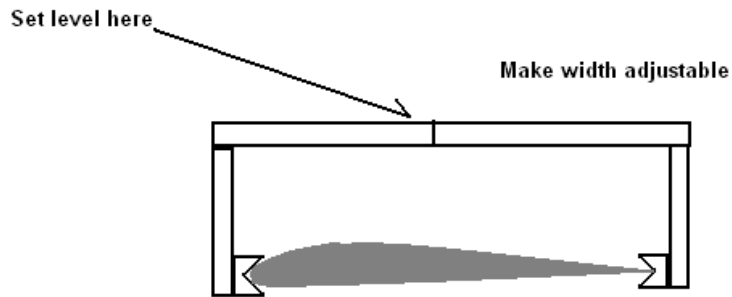

Rule 2. If a mono, support the aircraft and retract gear and flaps, if tri-gear, retract the flaps. Sit behind the aircraft on centerline and look at the trailing edge. Move your head up and down until you can see the shadow line of the lower surface. Look left and right. The shadow line should be even on both sides. The mean aerodynamic chord (MAC) is near the flap/aileron junction. Your outriggers will spoil your view, but at that point the left and right wing shadows should be dead even. This checks the wing is square and the incidence is correct. Some flaps have a little play and will droop under gravity, but fly up when airborne. Use a stick with very light pressure to hold them in place.

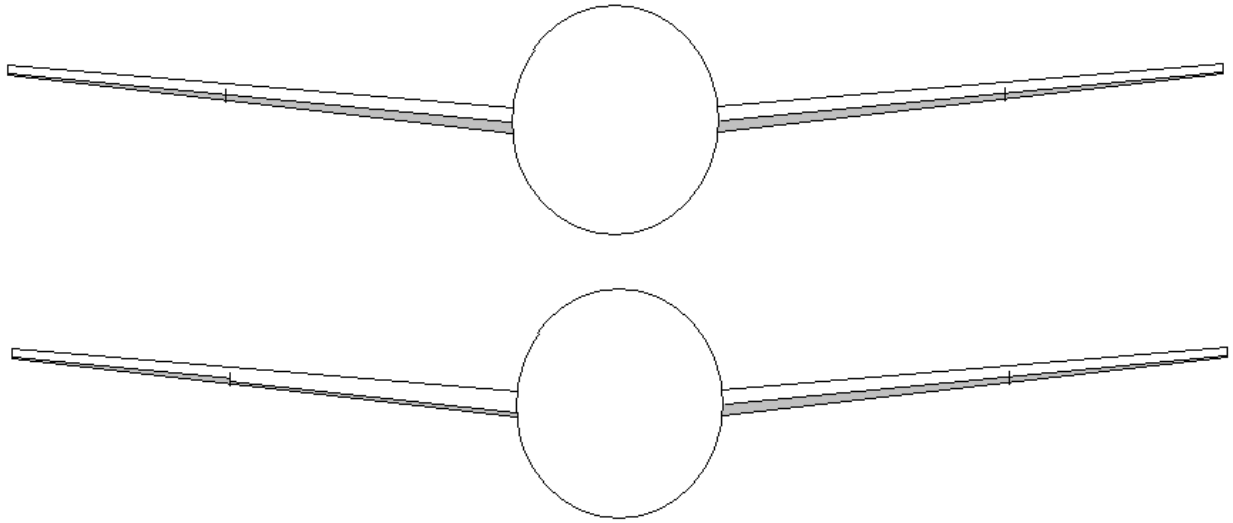

Look at the lower view. The left side has no shadow beneath, but the right from root to tip is consistent. The flap on the left is lower than the right. Or the wing is built with twist in it, so concentrate most of your effort on the MAC area.

Note: Why use your eye, because the eye is a superb level and square indicator, not suspect of measuring methods.

Rule 3. Check the tail surfaces are square to the wing and the rear fuselage is not twisted. Both stabs are exactly at the same incidence. Two degrees off on the stabs is like 1/8 aileron deflection.

Rule 4. Check the engine offset is per the manual at right thrust 1 1/16 inch offset to the firewall.

Rule 5. Check flap hinge coves and wheel pants for square. Remove if not aligned properly.

From my experience, the left roll is due to pilot weight. Higher thrust engines and CS props will add P factor even at an alpha of 2-3 degrees. Most planes using constant speed propellers need slight right rudder. This is easily trimmed by shortening the right rudder spring one or two links or putting in a cable shortener as depicted in the manual on the one side. (Trim tabs are ugly when stuck on a beautiful airplane and emphasize that there is a rigging error.) So preserve your ego and let the spring do the work for you. Yes I designed a rudder trim, and no I won't tell you but you can figure it out from above. Any roll with a drooped flap in flight needs to be compensated for, so jumping ahead:

Roll trimming during flight test:

Any roll corrections need to be done with the ball perfectly centered. Most EFIS ball indications are not as good as a good old fashioned ball and a distant cloud.

Center the ball first. Move aileron to stop the roll and re-center the ball. Note the aileron deflection by checking stick free with deflection required.

Note: By this I mean hold the stick for level flight, then release and note the movement of the stick. Reapply the stick deflection and note how much deflection stops the roll...Look outside too.

Land and evaluate.

Provided the aircraft has even stabs, proper incidence and the flaps are even, proceed to:

Adjust the flap which is up too far with the set screw in the baggage bay (Custom Flight Mod) or by adding a shim to the back of the baggage bay and the flap tube through the hole in the side of the aircraft with thin wedges to shim the flaps 1/32nd of an inch to correct roll. Right flap down rolls left.

Now, how to raise a flap. In essence, you will build in a crooked flap drive tube. My technique is to sand the opening to the flap tube of the flap I need to raise should the tube contact the opening. Then adjust the flap actuating tube to pull the flaps full up. Next you take out or loosen the AN3 bolts from the flap hinge arms (FL 16s) that attach to the tube and replace with loose bolts or clecos. Adjust the flaps to the proper position and lock in place with boards to the floor. I then shim the flap tubes near their fuselage exit to fix the flaps to where they need to be. Retighten the bolts or if slightly misaligned, open them up to 1/4 inch if the holes no longer align to get the fuselage flap pivots to work well... This repositioning of the FL 16 is necessary and must be done so as to raise the flaps without binding. If you don't take the stress off the flap actuating arm, it may give problems retracting the gear. See flap tube adjustment JPEG image below.

Should the flap tube of the flap you must raise (left) be hard against the baggage bay bulkhead, you have no recourse but to droop the opposite (right) flap to raise the right wing. How much, I typically go for 1/32- 1/16 inch max. A flap is a huge trim tab. This will cause drag on the right and more left rudder to fly straight. Be cautious when drooping a flap.

On some planes I actually have a screw and T-nut in the baggage bay bulkhead to adjust the flaps on a tri-gear for fine tuning. It is slick, but dangerous if a novice just starts screwing away without care. See drawing below.

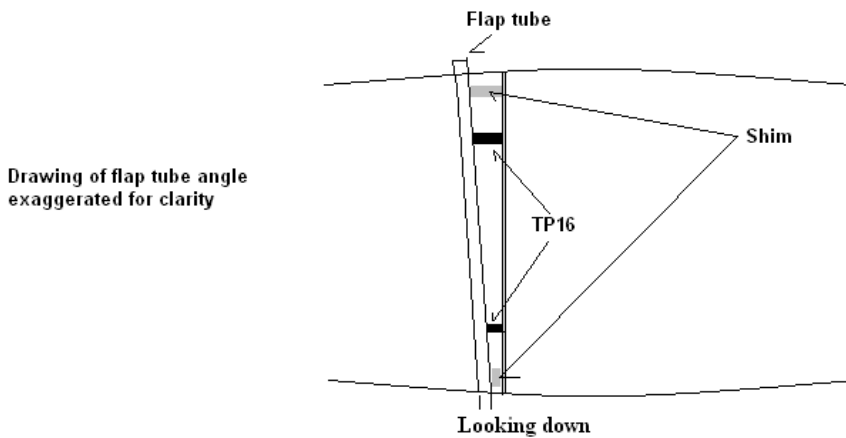
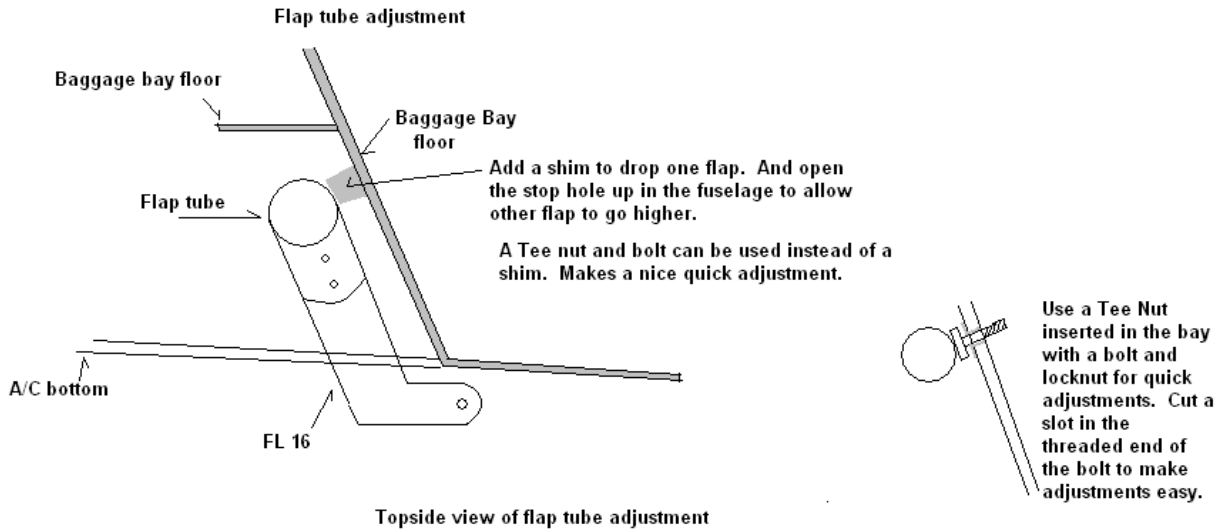

Again, go fly and evaluate. When roll is cured you may need to adjust the aileron to match. But wait, most likely, then it needs the flap to be trimmed again for less deflection due to the aileron trimming, or because you made the airplane with very little friction in your roll system and a bit of QD slop, you may see both ailerons now evenly up or down as appropriate. Fix the slop, and go fly again. Test trim, then re-do a stall series.

If the wing tip is off, and/or an aileron tab is needed, re-contour the aileron. To do this, sand one inch back on the lower trailing edge of the aileron which needs to fly up and add filler (Evercoat Rage works great) to make a wedge that tapers from zero to 1/16 of an inch along the full span. Think of it as a long wedge of nearly no weight. Go fly. Land and sand, then go fly until it is trimmed. Paint as required. This makes a virtually invisible aileron trim tab and the thickness is very difficult for the untrained observer to catch. See the picture for clarification below:

Typical Europa Aileron

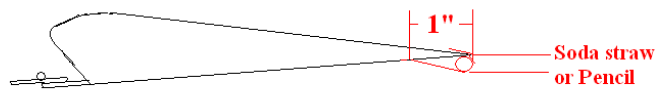

To test, place 10 inch pencil or straw on trailing edge and tape it in place making a ramp about 1-1.5 inches long. If the tab is 10 inches long that corrects a pound of stick force and will require a filler strip of 1/16 inch for nearly the length of the aileron.

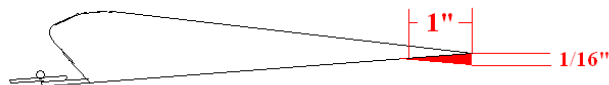

Filler added like a ramp or flap

The filler strip is to hide the fact you needed a trim tab. It is called **contouring the aileron.**

Once the aircraft is rigged with the ball centered. Now go back and fly at your preferred power setting and altitude and trim out the rudder using the same technique above, or if you remember the rudder cable shortening technique from the Builders Manual page 22-5, just shorten the cable on the side you are holding rudder on and let the spring be your trim tab.

Enjoy making your plane perfect, it is worth the effort.

Bud Yerly
Custom Flight Creations