

Revmaster

CDI IGNITION SYSTEM

The Revmaster CDI ignition system is a dual plug capacitor discharge ignition which is self-energized and does not need a battery once the engine has been started.

The system includes two 18 amp alternators, two rectifier/regulators, flywheel, high torque starter and eight ignition coils. Fig. 10.

The accessory housing also allows for the engine mount attach points which will interface with engine mounts for KR2's, Sonex, etc.

The system does not contain bearings, points, or gears that need servicing.

The timing is set by adjusting the pulsar wheel in relation to the position of the number one piston which is 25° before top dead center.

The circuitry is encapsulated in a finned housing. This housing can be disconnected and removed as a module for replacement if necessary. Fig. 6.

The system is equipped with a high torque geared starter. Once the starter is engaged, the ignition starting circuitry is boosted by 12 volts from the solenoid. After the engine starts, the solenoid cuts the voltage from the battery. Fig. 9. The ignition then operates off the dual energy coils on the stator A & B. Fig. 2.

Unlike most magnetos which contain one coil, the Revmaster CDI contains eight high tension coils which are shielded and positioned at the spark plug, thereby eliminating 25 feet of high voltage plug harness. Fig. 7 & 8.

If the coil fails on a standard magneto, the system will lose four spark plugs out of eight. If the Revmaster CDI has a coil failure, only one plug is affected. If one circuit out of four fails, two plugs are affected in opposite cylinders. Fig. 3.

The flywheel assembly contains twelve neo-35 special cast magnets and a ring gear for the starter. The magnets provide the energy for the alternator and ignition via the stator. The alternator weight is in the flywheel, thereby assisting the engine to run smoothly without the normal maintenance of belt driven alternators. Fig. 5

REVMASTER

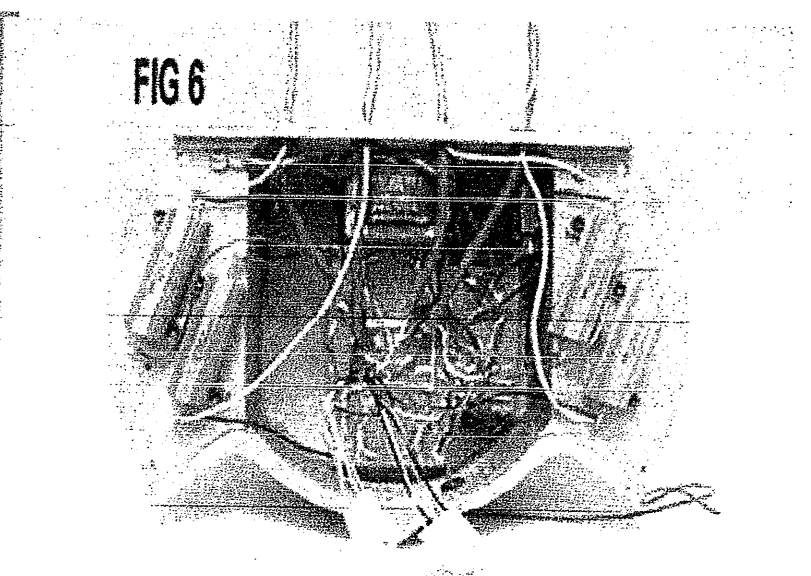
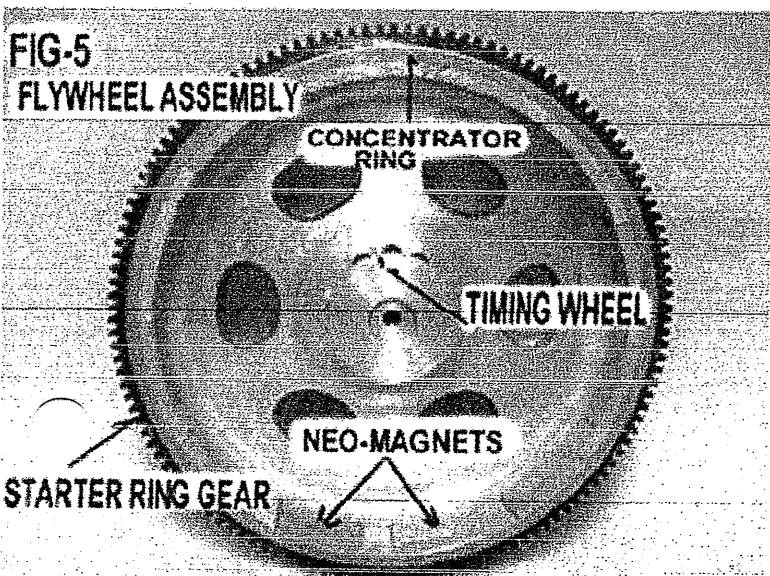
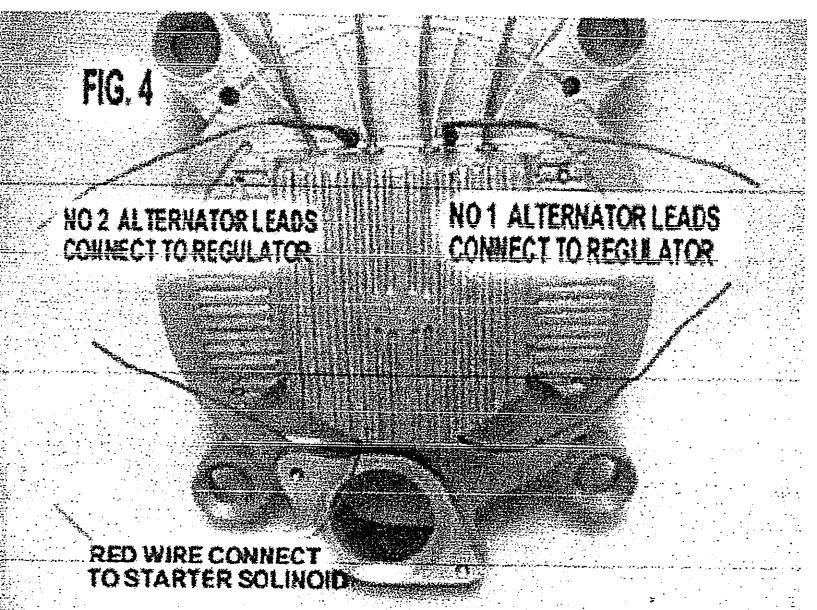
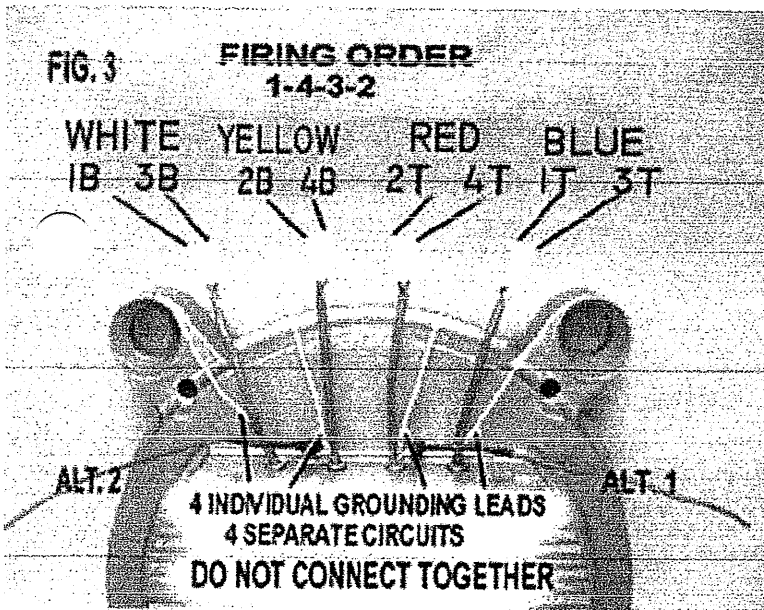
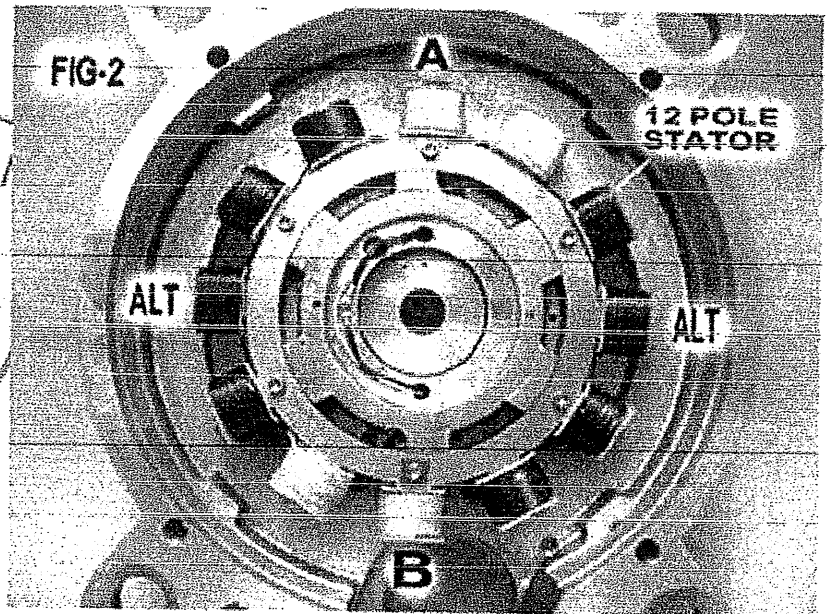
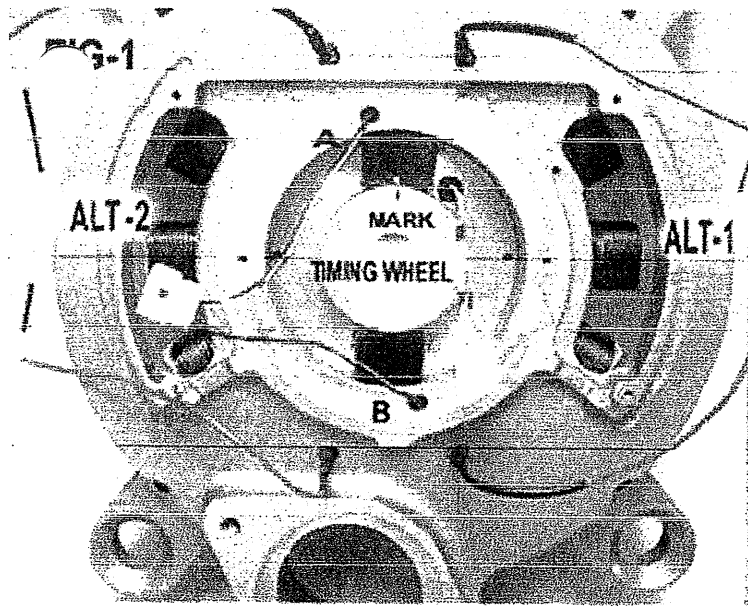

REVMMASTER

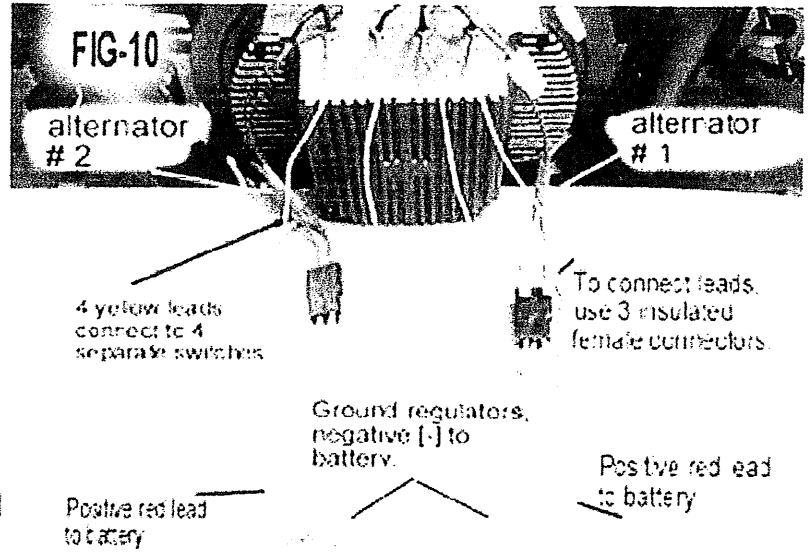
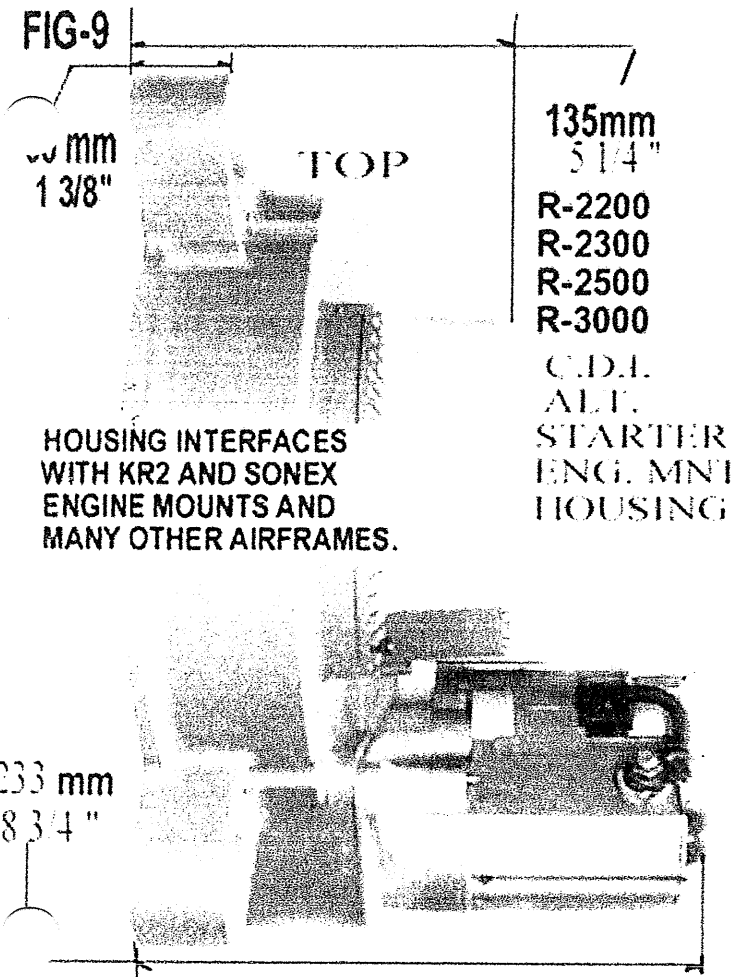
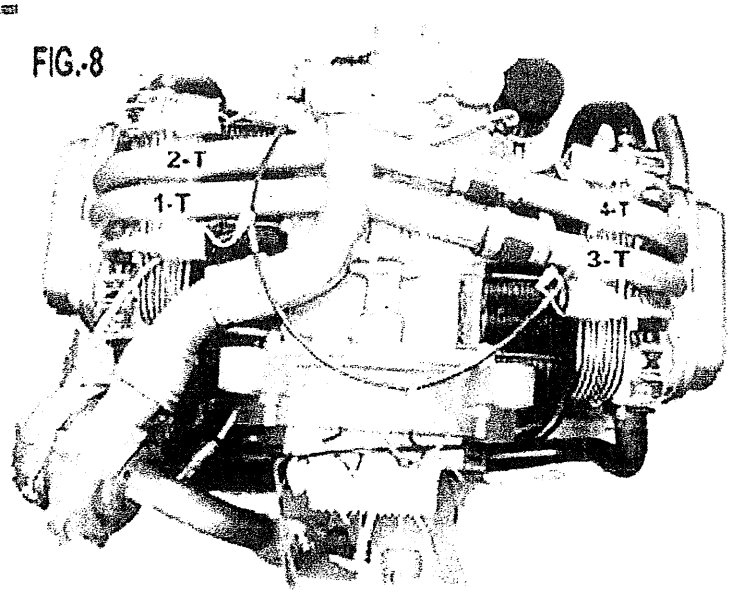
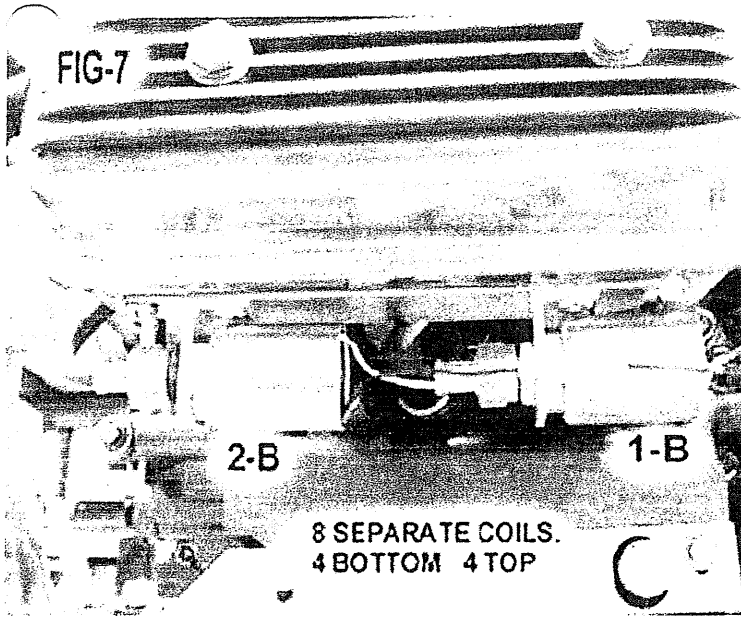

ENGINE S/N

CDI S/N

DATE

GENERATOR COIL CHECK

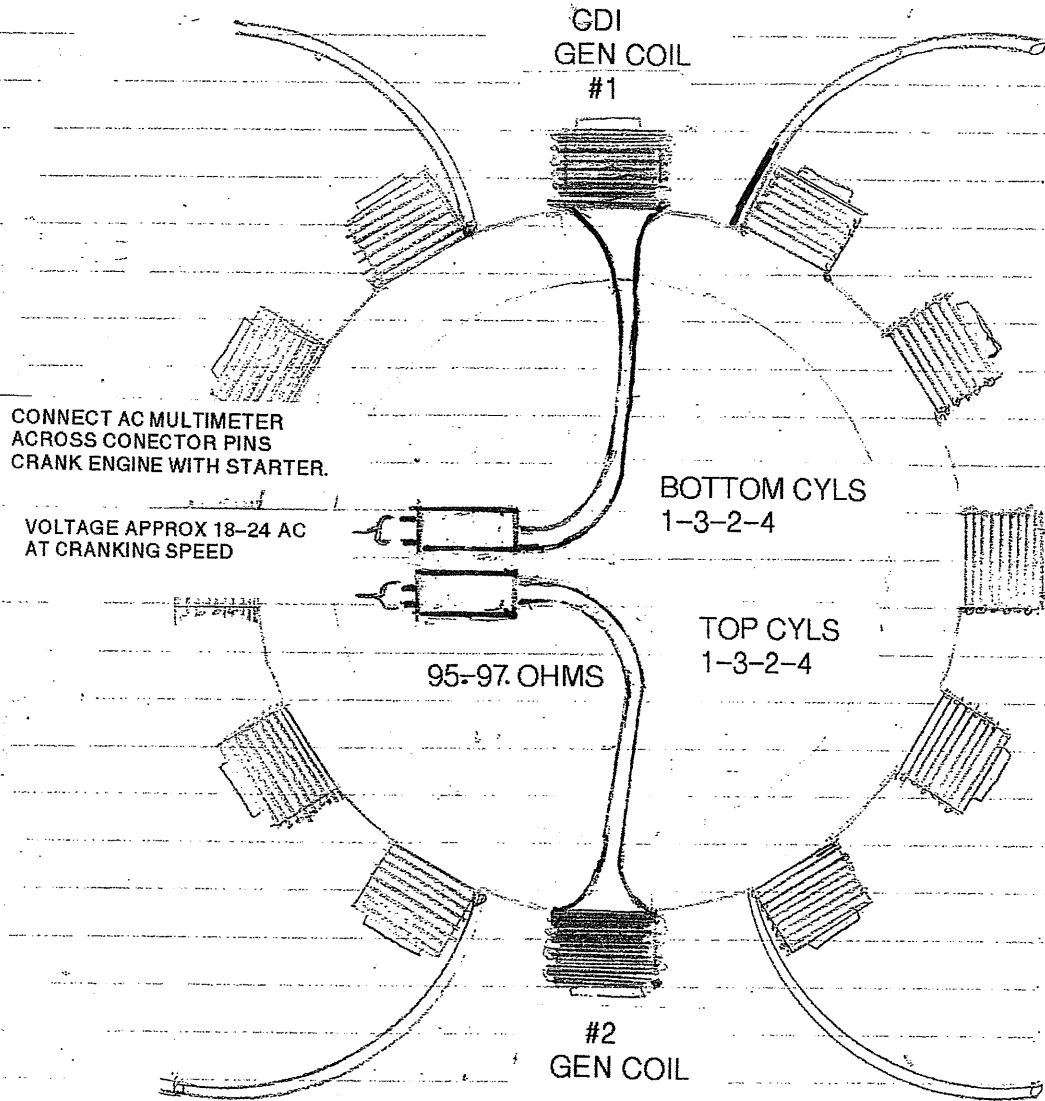

GENERATOR COIL CHECK

MEASURE OHMS & AC VOLTAGE

OHMS #1 _____

#2 _____

AC VOLTS #1 _____

#2 _____

REVMASER HESP.

8-29-13

ENGINE S/N _____

CDI S/N _____

DATE _____

FOUR SEPARATE CIRCUITS
DOUBLE WOUND COILS

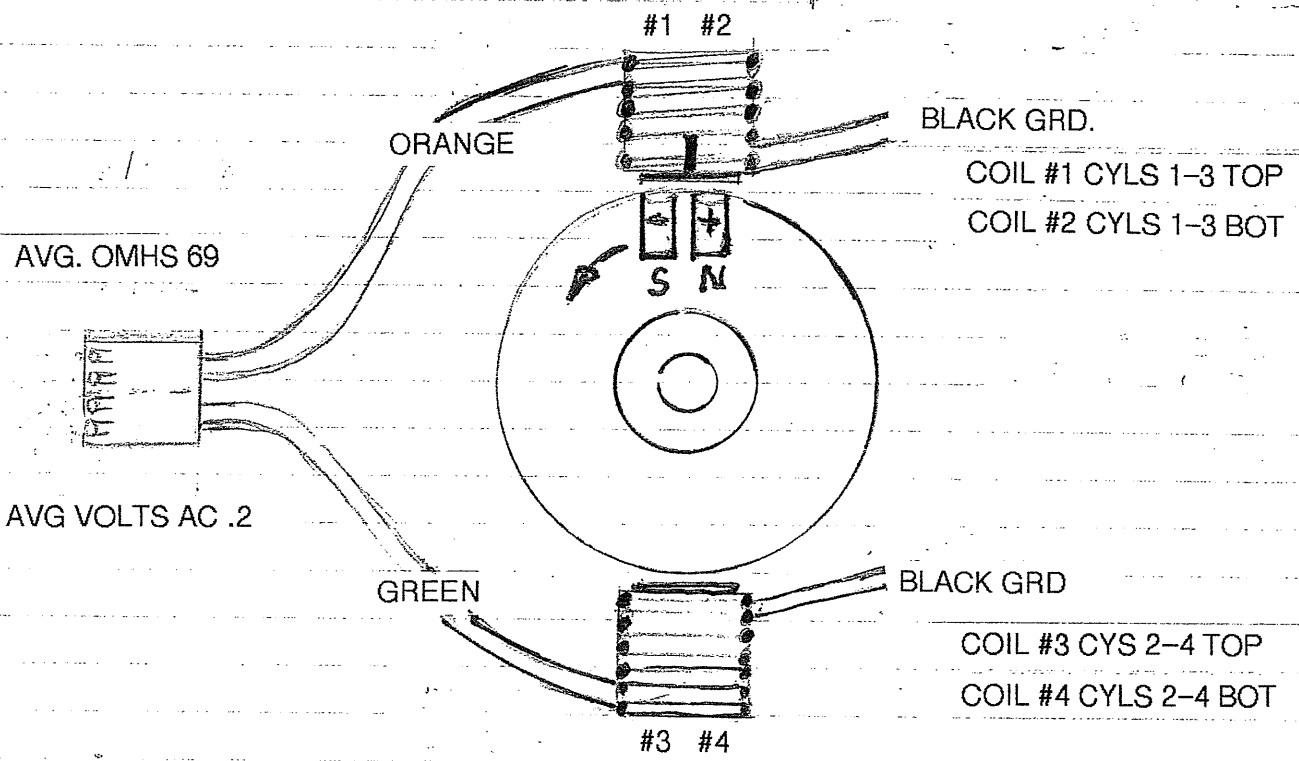

PULSAR COIL CHECK
MEASURE AC VOLTAGE
AT CRANKING SPEED

OHMS	#1	#2	#3	#4
	_____	_____	_____	_____
AC VOLTS	#1	#2	#3	#4
	_____	_____	_____	_____

REVMASTER CDI IGNITION

REV 3 4/8/13

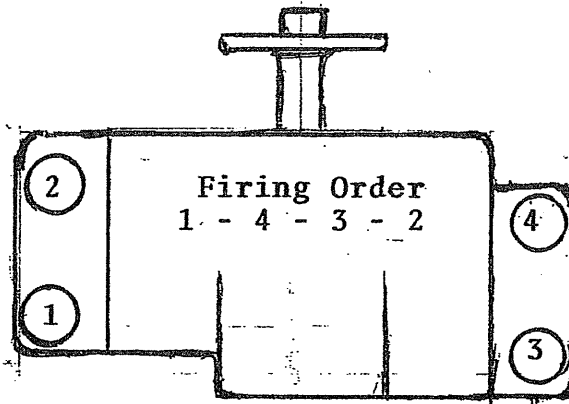

BOTTOM PLUGS

TOP PLUGS

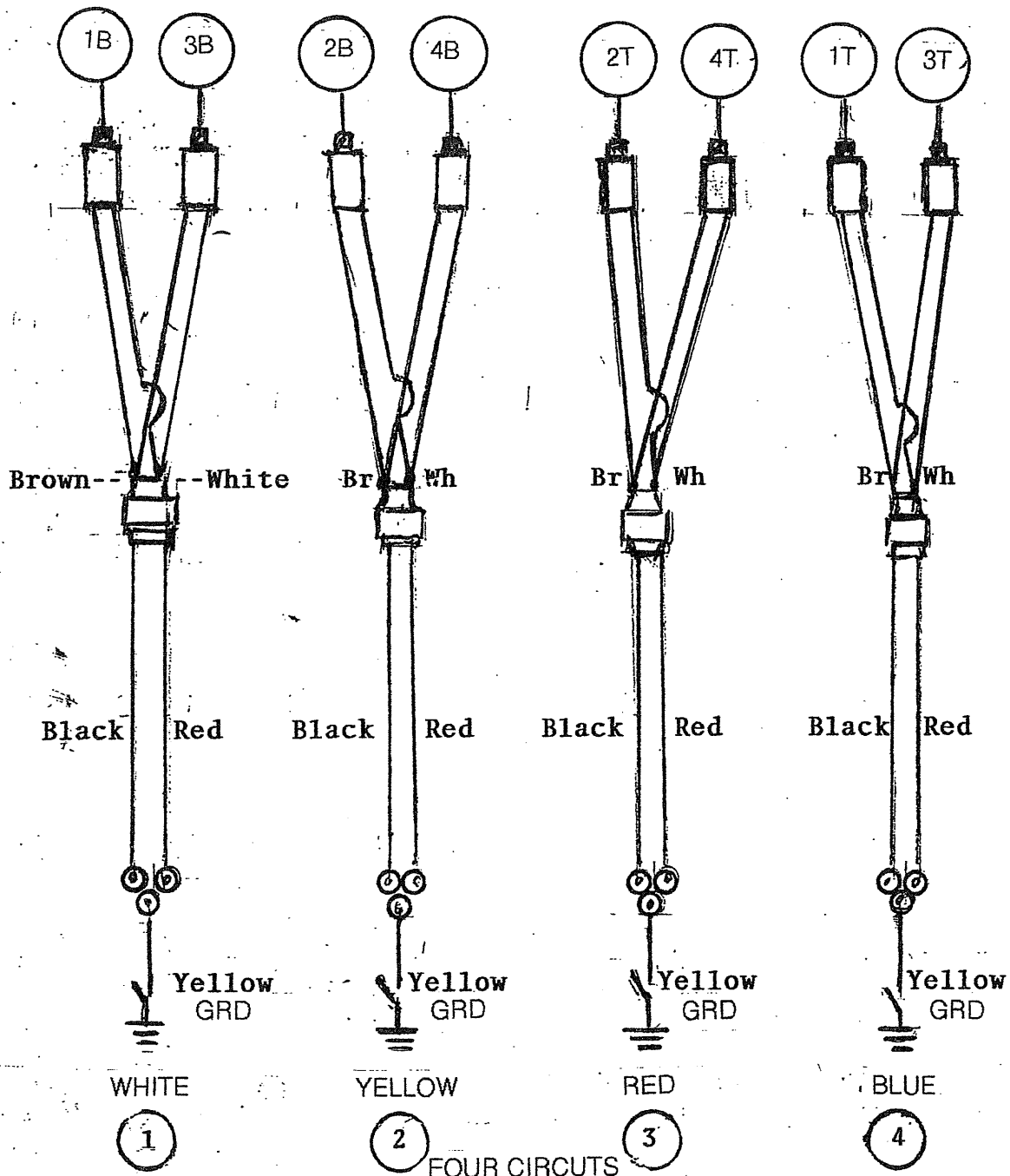

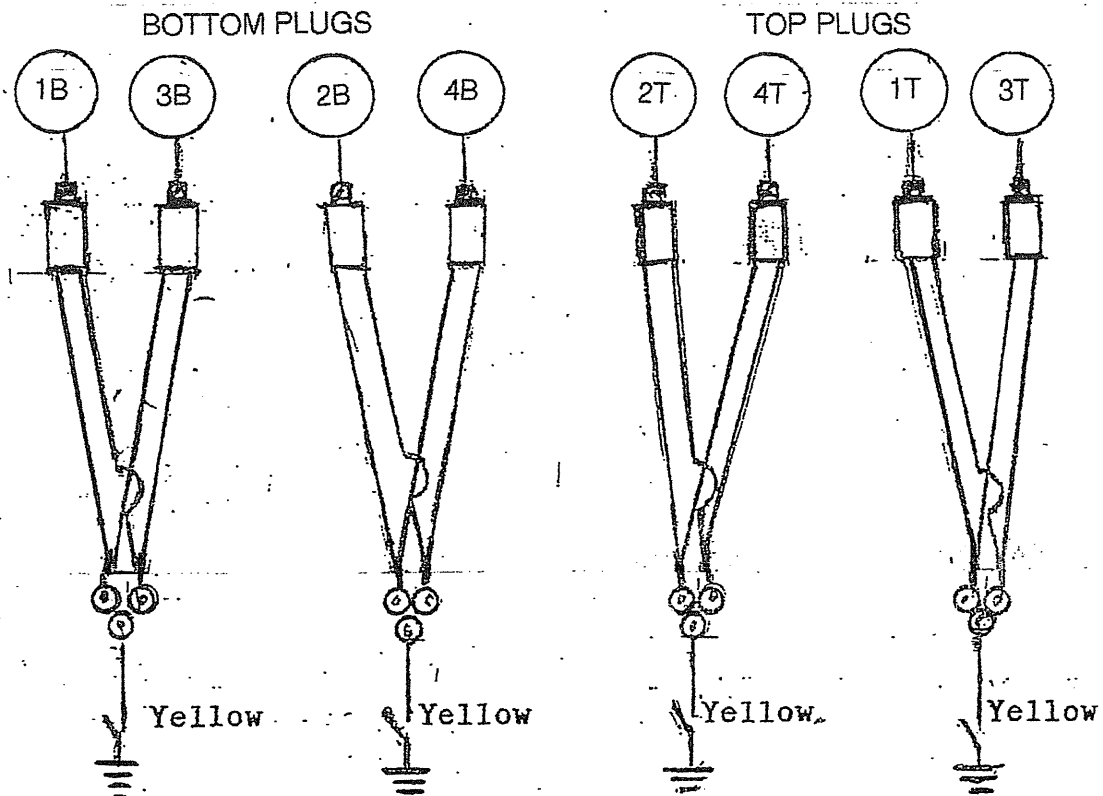

FOUR SEPARATE CIRCUITS

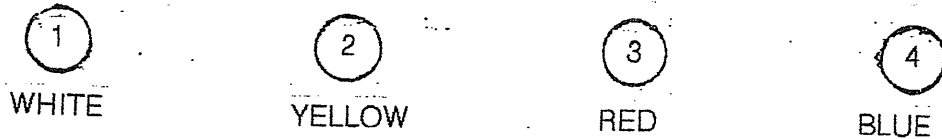

GROUND CIRCUITS 1 & 2, ENGINE WILL RUN ON TOP PLUGS ONLY.

GROUND CIRCUITS 3 & 4, ENGINE WILL RUN ON BOTTOM PLUGS ONLY.

GROUND CIRCUITS 1 2 & 3, ENGINE WILL RUN ROUGH ON 2 CYLS 1T & 3T
IF 1T or 3T IS DEFECTIVE, ENGINE WILL NOT RUN ON ONE CYLINDER.

GROUNDING ANY THREE CIRCUITS WILL CHECK THE REMAINING CIRCUIT.

CIRCUIT CHECKS CAN BE DONE AT 1200 - 1500 RPM.

WARNING: DO NOT LEAVE ANY CIRCUITS GROUNDED FOR EXTENDED PERIOD OF TIME WHILE ENGINE IS RUNNING.

CDI CIRCUIT CHECK
R-2100 R-2200 R-2300

REV 3 4/8/13

28-06-00	Flywheel assembly								
28-06-01	Flywheel 30-02-03								
28-06-02	Concentrator ring								
28-06-03	Magnet 30-02-02								
28-06-04	Ring gear								
28-06-05	Cover plate								
28-06-06	Screw								
28-06-07	Washer								
28-06-08	Bolt, flywheel								
28-06-09	Washer, flywheel								
28-06-10									
28-06-11	Timing wheel assembly								
28-06-12	Wheel								
28-06-13	Magnet								
28-06-14	Spacer, magnet								
28-06-15	Cover								
28-06-16	Screw								
28-06-17	Washer								
28-06-18	Bolt								
28-06-19	Washer								
28-06-20									
28-06-21									
28-06-22	Housing assembly								
28-06-23	Housing								
28-06-24	Timing plate								
28-06-25	Cover, circuitry								
28-06-26	Screw								
28-06-27	Harness								
28-06-28	Circuitry, ignition								
28-06-29	Coil, timing plate								
28-06-30	Coil, ignition								
28-06-31									
28-06-32	Stator assembly								
28-06-33	Plate, stator								
28-06-34	Rivet								
28-06-35	Bobbin								
28-06-36	Winding, copper, .060								
28-06-37	Lead								
28-06-38	Screw								
28-06-39	Washer								
28-06-40									
28-06-41	Rectifier/regulator								

Revmaster Aviation, L.L.C.

RECTIFIER/REGULATOR

R-2100 R-2200 R-2300

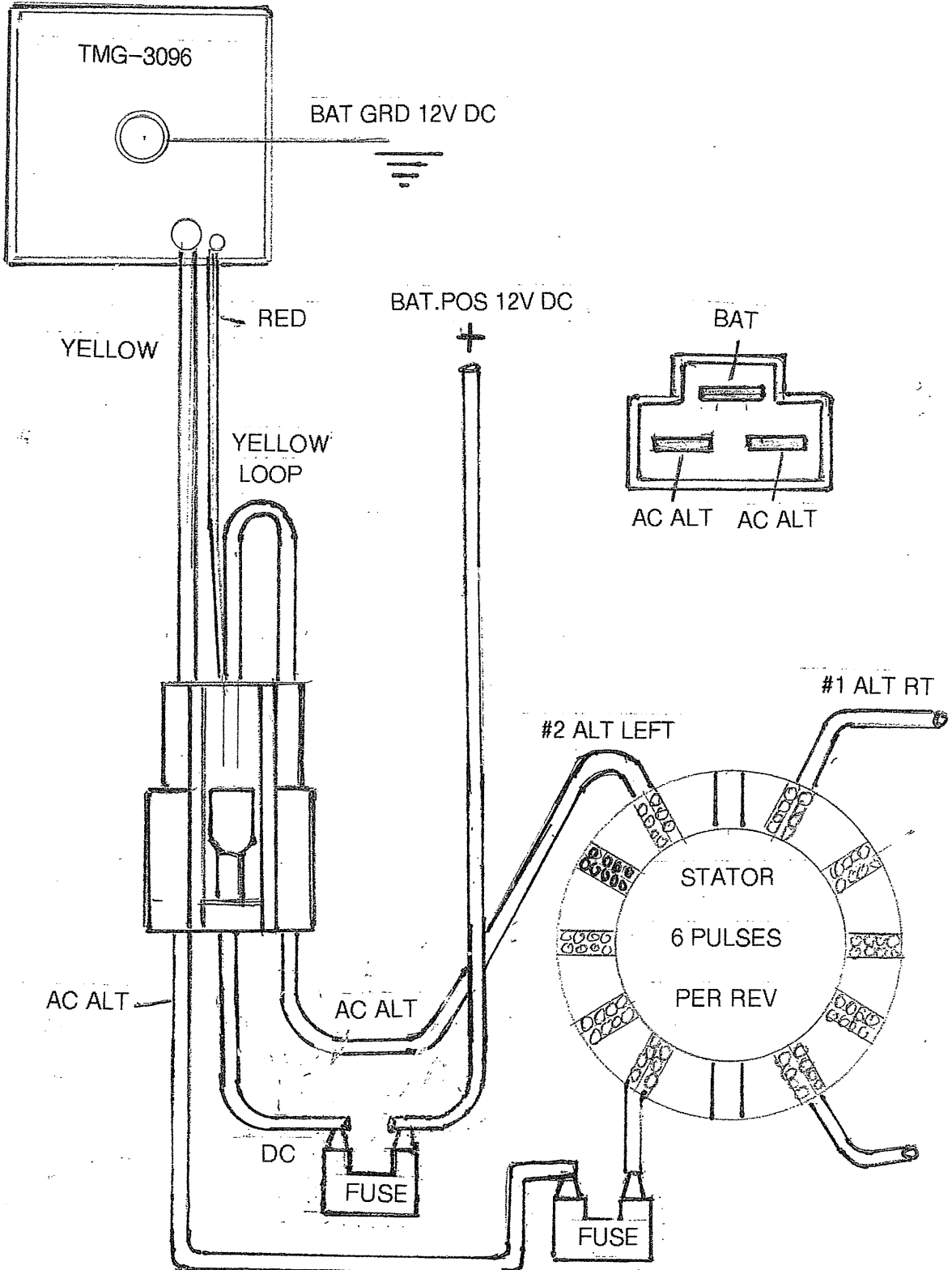

4/1/13

CONNECT TACH TO ALT BEFORE THE REGULATOR

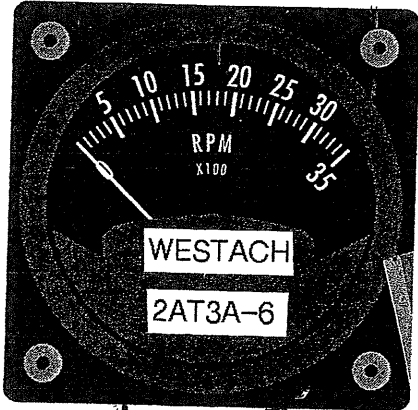

6 PULSES PER REV.

-AC

AC

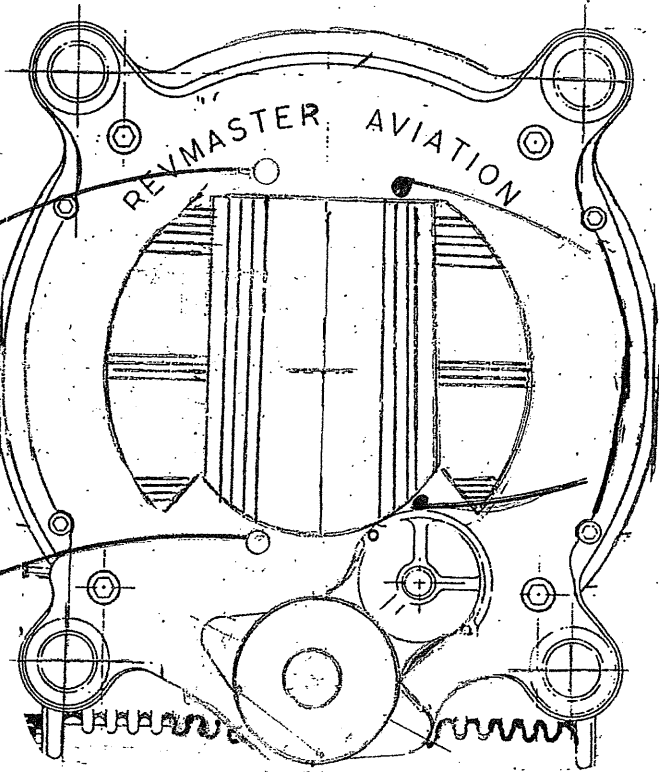

R-2100 R-2200 R-2300

