

AND STOPS FORWARD OF MAIN SPAR (SEE  
 BOTTOM PORTION OF MOULDING TO GO OVER  
 MAIN SPAR TOP).

AILERON DEFLECTION SEE 6-W-10

**FLAP DEFLECTION**

DOWN: Max 30°

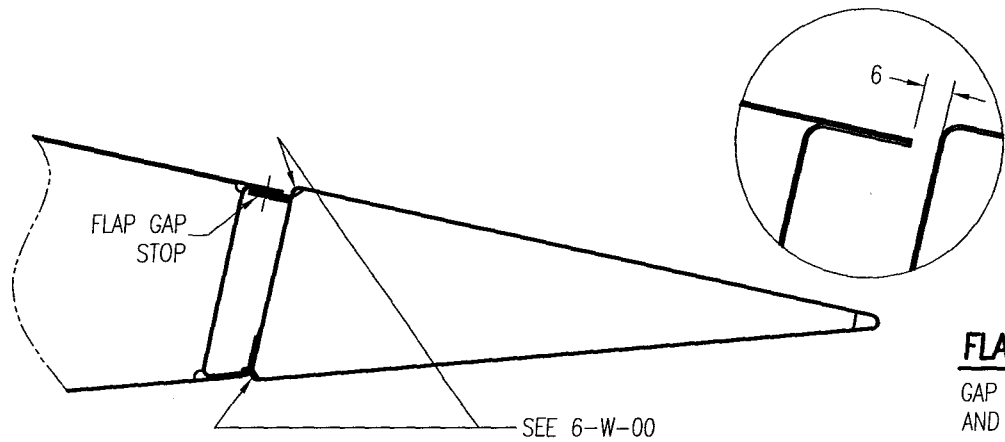

**FLAP NEUTRAL**

GAP BETWEEN AFT EDGE OF TOP SKIN  
 AND FRONT EDGE OF FLAP

IMPORTANT: FLAP LIMIT STOPS ARE SET WITH  
 POSITION OF MICRO SWITCH ON FLAP ACTUATOR.

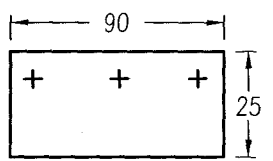
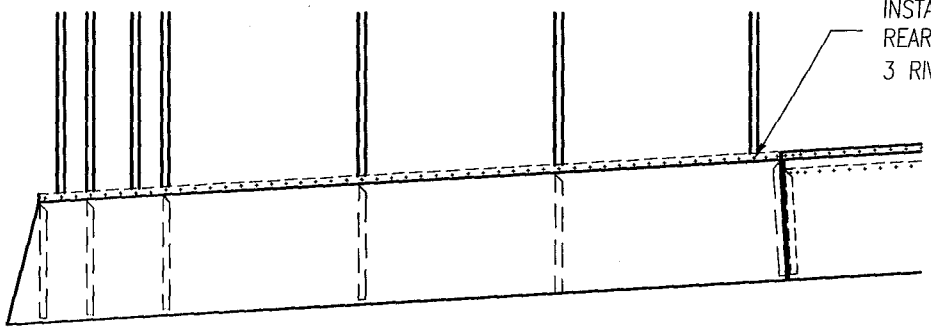

**FLAP GAP STOP**

PLASTIC BEARING MATERIAL t=1/8" qty=2

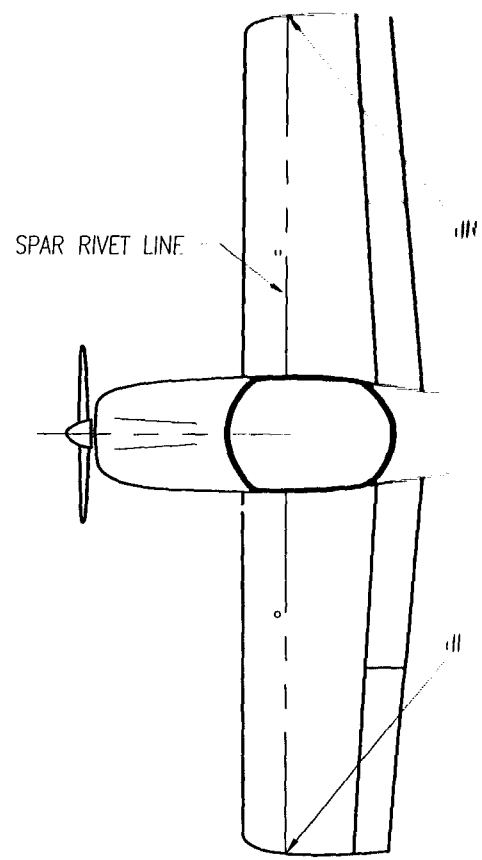

CHECK FOR EQUAL DISTANCE BETWEEN  
 LEFT AND RIGHT WING TIP TO A FIXED  
 POINT BY TAIL ON FUSELAGE CENTER LINE.  
 dL=dR TOLERANCE +/-50mm