



Step 1: Separate the F-10110A Wire Cover and the F-10110B Clip as shown in Figure 1 then deburr.

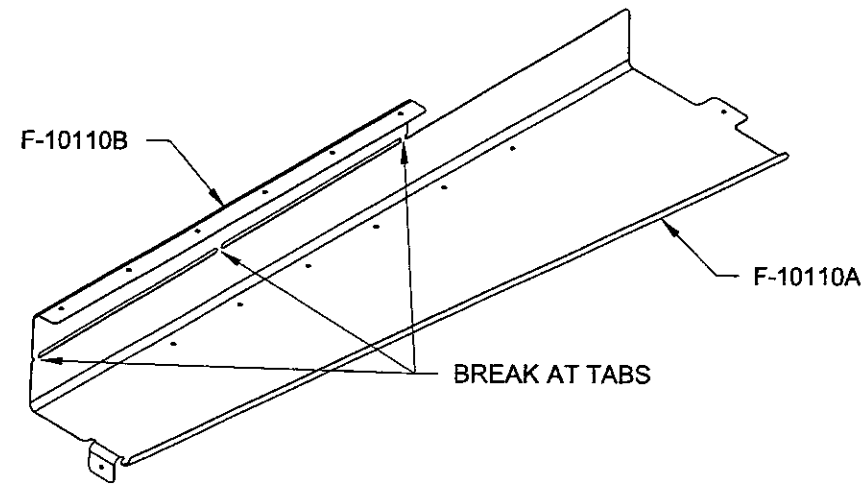

FIGURE 1: SEPARATING WIRE COVER PARTS

Step 2: Cleco together the F-10110A Wire Cover and F-10110B Clip creating the F-10110-L Wire Cover Assembly and final-drill as shown in Figure 2.

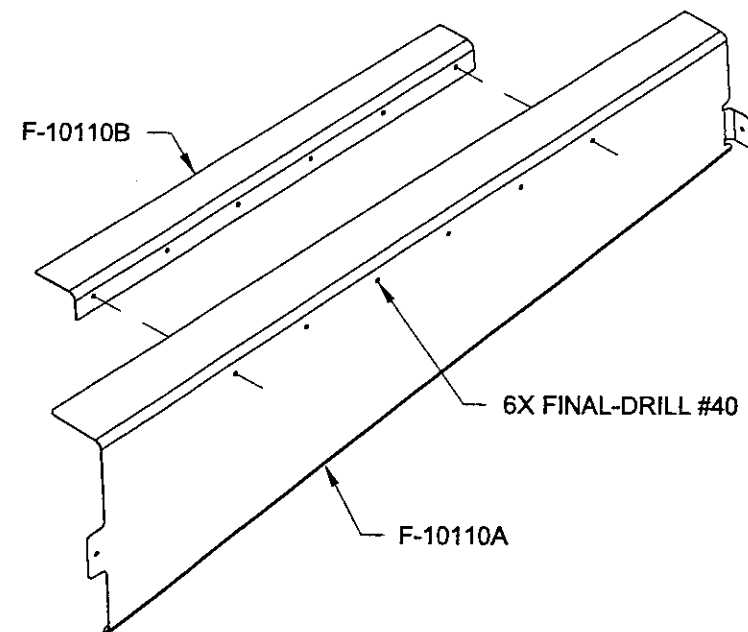

FIGURE 2: FINAL-DRILLING CLIP AND WIRE COVER

Step 3: Test fit the F-10110-L Wire Cover Assembly to the F-1013-L Fwd Fuselage Longerons (not shown). Adjust the bend angle of the F-10110B Clip if/as required until a snug friction fit is achieved.

Step 4: Install the F-10110-L Wire Cover Assembly as shown in Figure 3 with the aft tab on the inboard side of the F-1015D-L Mid Cabin Side Cover. Match-Drill the mid cabin side cover and the F-1042-L Bulkhead Side Channel using the hole in the aft tab of the wire cover assembly as a guide.

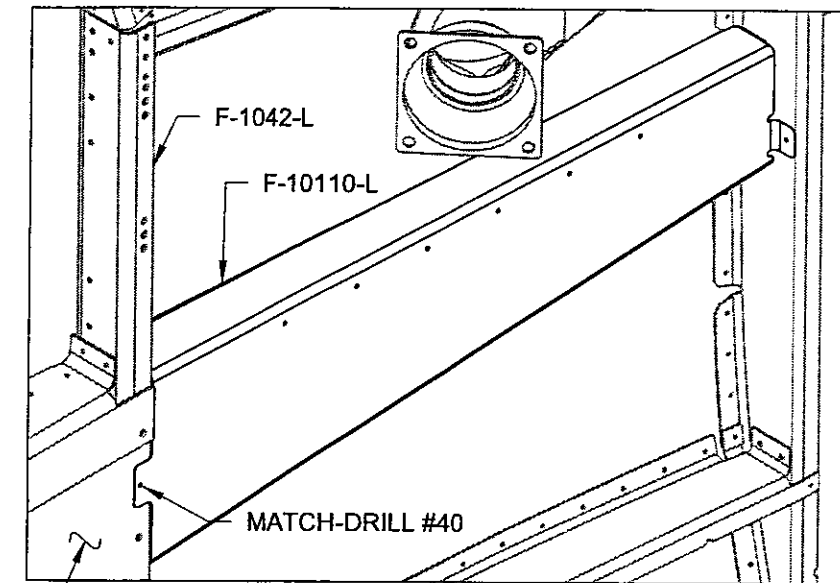

FIGURE 3: MATCH-DRILLING THE WIRE COVER, MID CABIN SIDE COVER AND BULKHEAD SIDE CHANNEL

Step 5: Remove the F-10110-L Wire Cover Assembly. Replace it positioning the aft tab on the **outboard** side of F-1042-L Bulkhead Side Channel as shown in Figure 4. Drill as per the callouts. Remove the wire cover assembly, disassemble, deburr and dimple the #40 holes.

Remove the F-1015D-L Mid Cabin Side Cover. Deburr the holes in the mating parts. Machine countersink the bulkhead side channel and dimple the mid cabin side cover for the hardware called out on Page OP37-17, Figure 1.

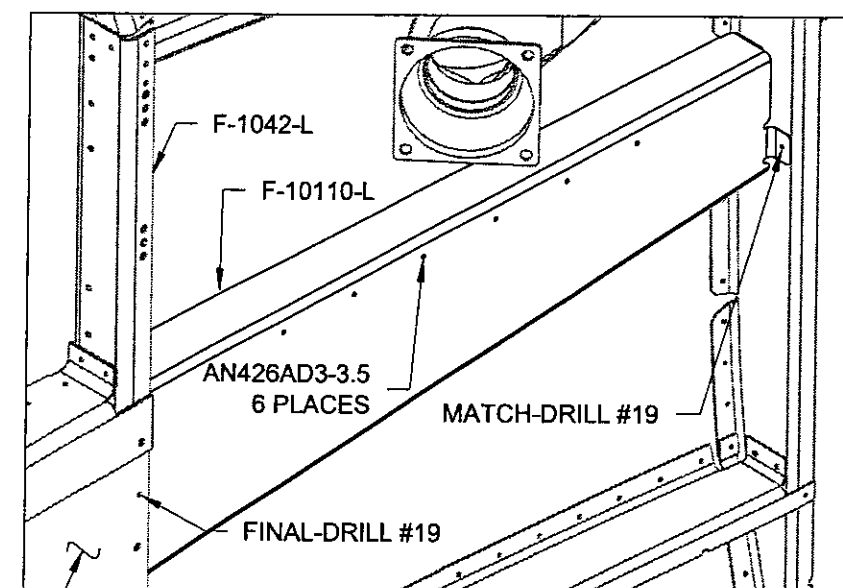

FIGURE 4: FINAL-DRILLING THE SIDE COVER, CHANNEL AND WIRE COVER