

YAK-52 OIL SCHEMATIC

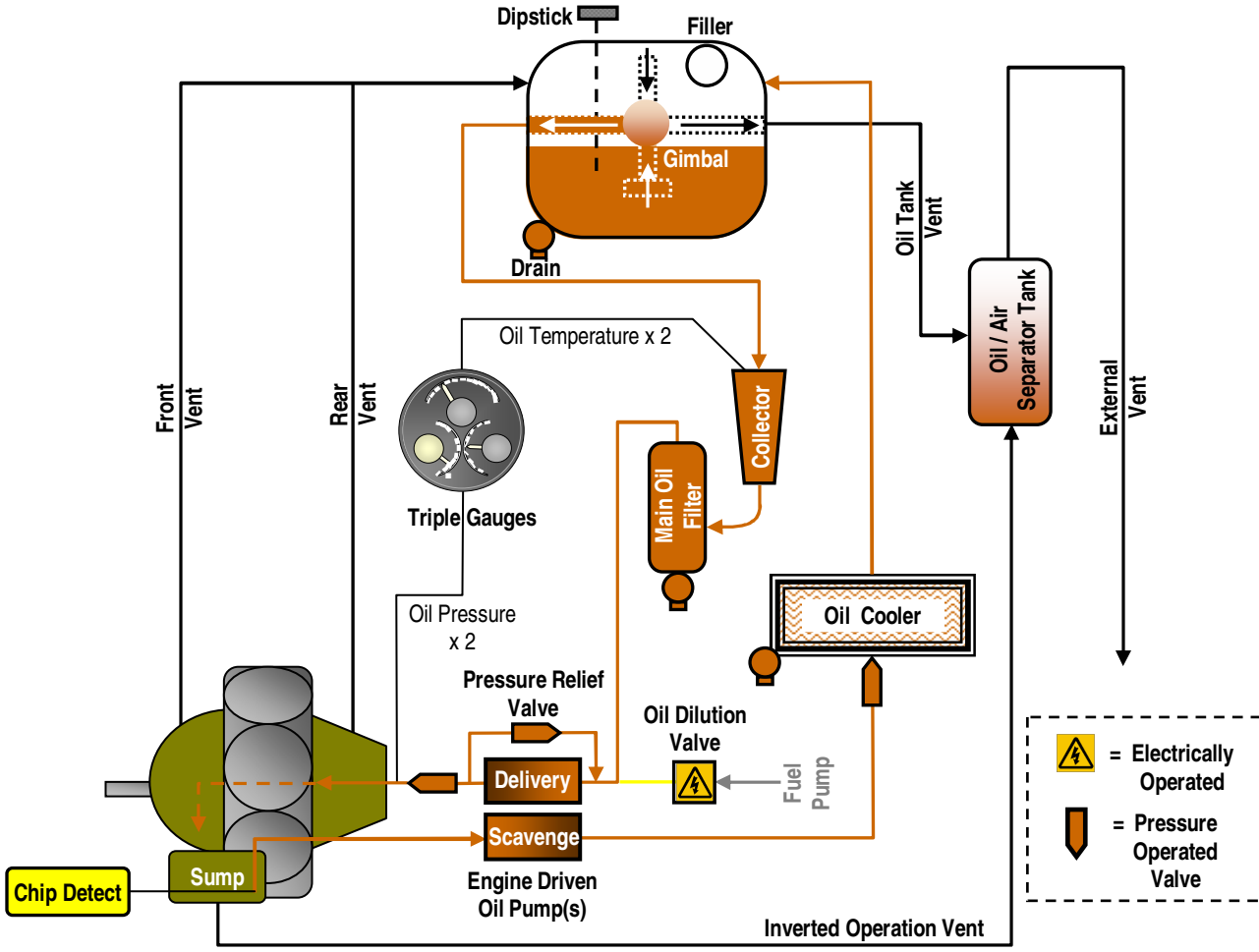

Note : constant speed propeller governor & propeller hub oil feeds not shown

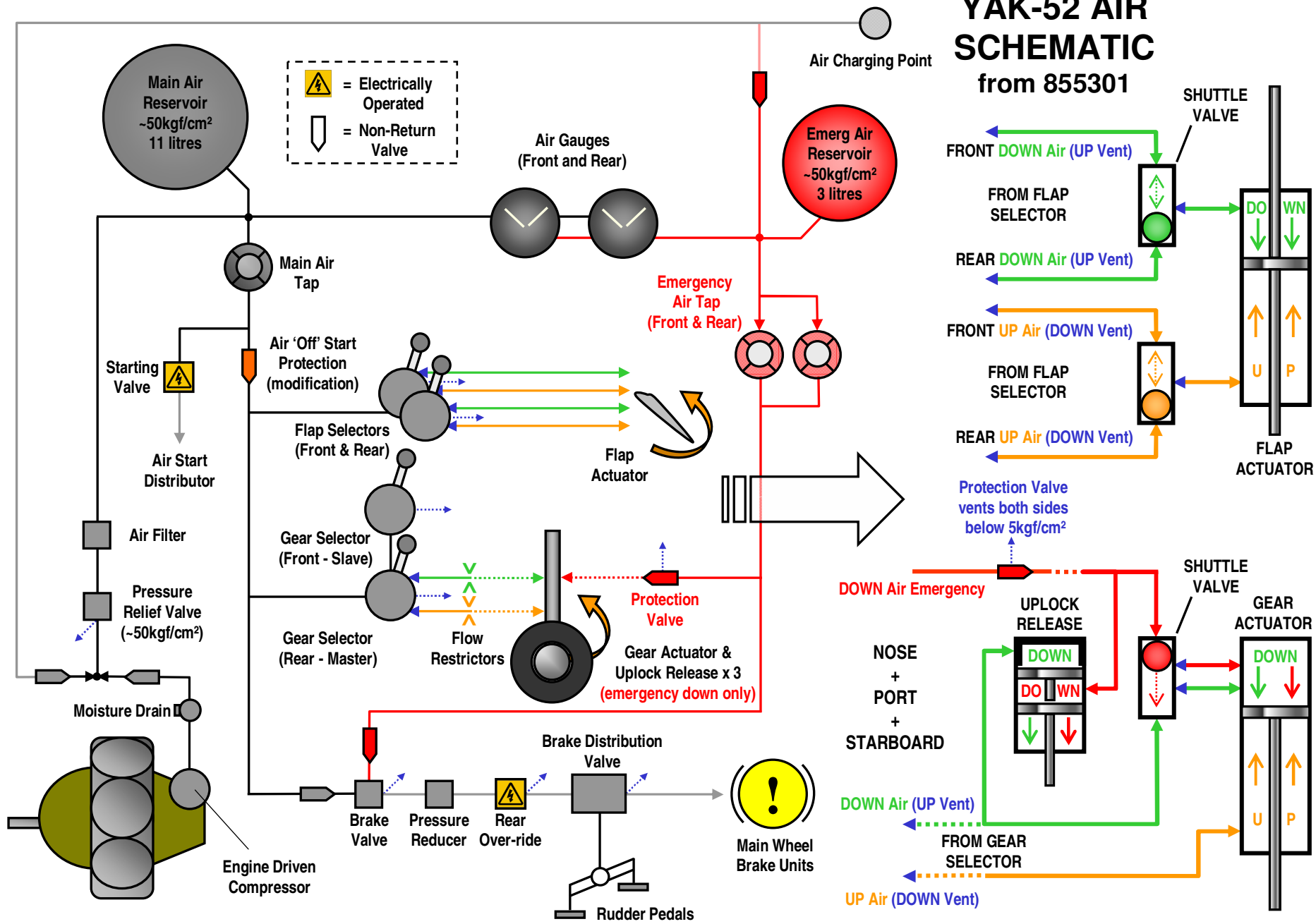

YAK-52 AIR SCHEMATIC to 855215

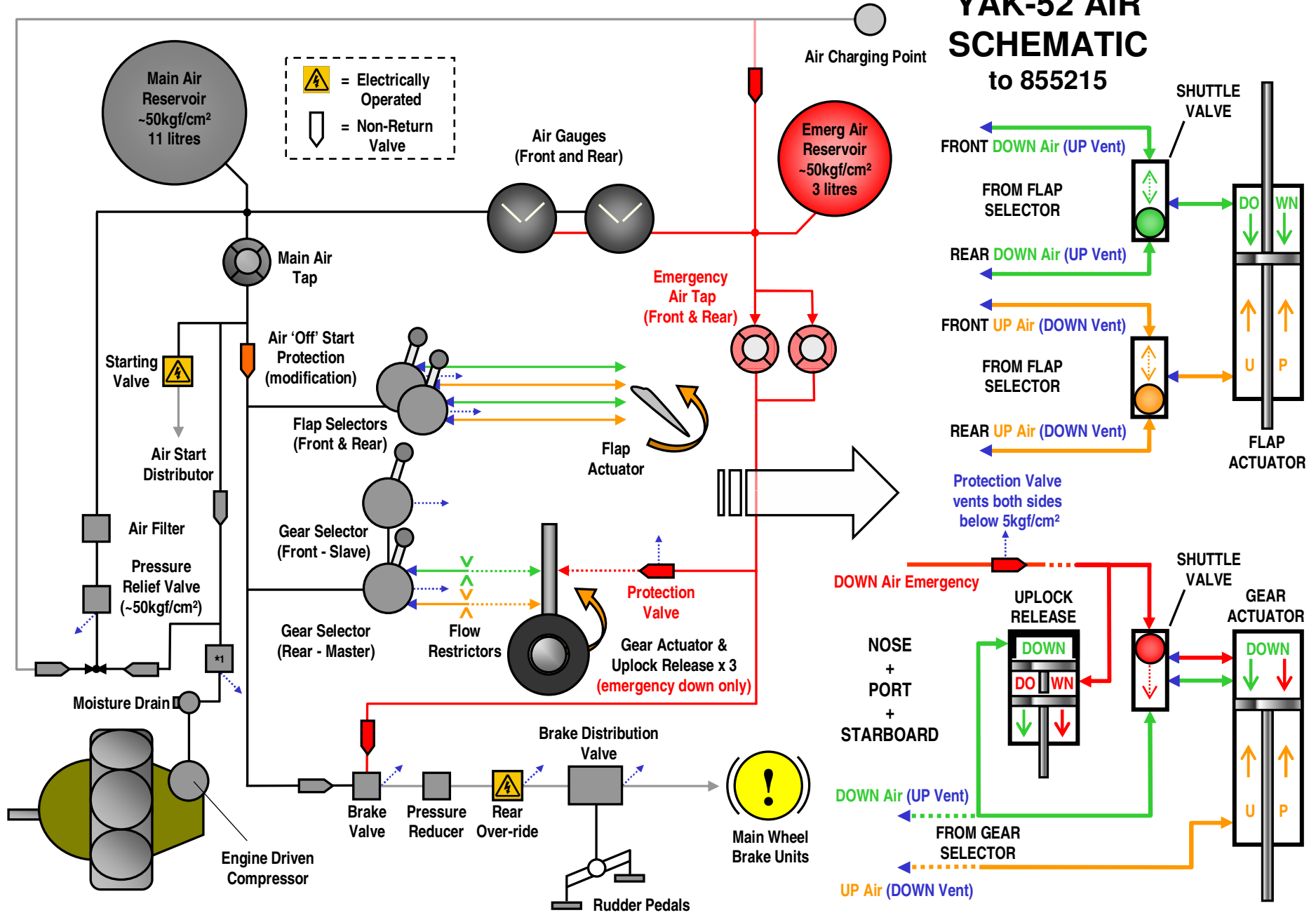

*1 Air Actuator [opens & isolates input to atmosphere when output ~50kgf/cm²]
(most aircraft refitted to 855301 configuration when overhauled)