

Fuel Tank Installation Modification  
By  
Bud Yerly  
Custom Flight Creations, Inc.

The Europa fuel tank is made from what is called TPFE. Basically nylon with flourine added. Epoxy sticks to the tank very well with only a small cleaning, but rest assured, if you choose to glass it in hard, it will stick very hard with only a bit of sanding and of course cleaning off any release agent or grease. I will be forwarding to Europa a service bulletin before long on the tank. The original manual refers to the older tanks which epoxy didn't stick to well and in the event of some movement, the tank would unstick and float on its supports and not crack. It also made for an easy removal. The new tank really sticks to epoxy and in the flexing of the tank with fuel weight and fuselage movement, the tank can, in some conditions crack.

This all came about after a flurry of calls on tank leaks. Soon, I had to replace my circa 2000 tank. After being defueled for some four years, when I refueled again, the tank cracked after a week or so. I did an autopsy of the tank and found the tank cracked near the bottom due to bending. The autopsy of the tank revealed exactly where the bends were, and they were all just above the glass reinforcing points. Apparently, the tank does harden with age, as all plastic does, when refueled with the extra weight, the plastic doesn't tolerate a lot of flexing until the fuel and warmth softens up the tank. Others have found similar cracks in the same area, and or around the saddle. I did a quick and dirty analysis of the bending on my tank, and the area around the saddle and the bottom and back of the tank was permanently bowed out due to the tank being supported only by the back corner of the tank and right on the top part over the spar.

Note the picture below:

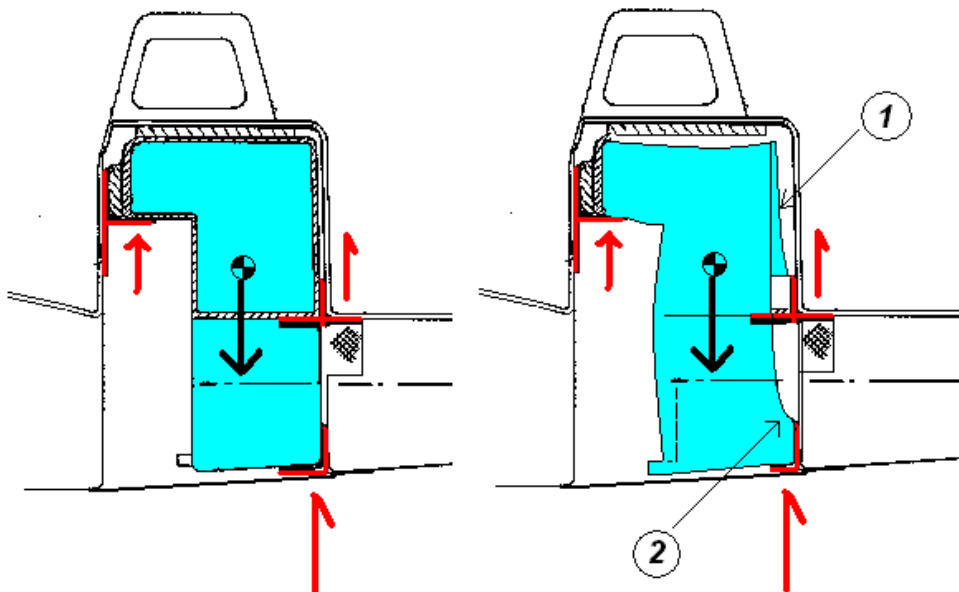

My analysis of the tank cracks is shown in the picture below:

### Quick and dirty stress analysis

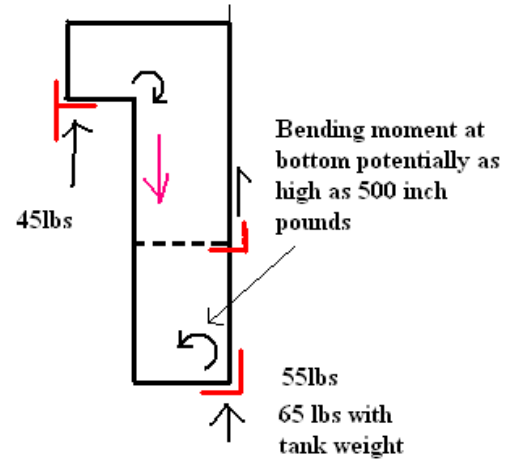
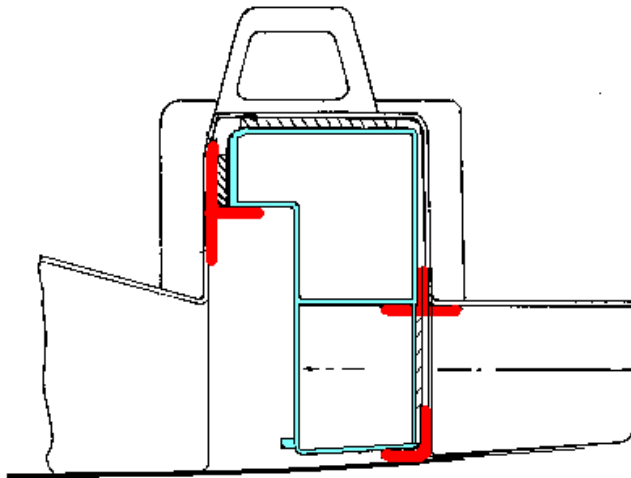

Bending moment at bottom potentially as high as 500 inch pounds

55lbs  
65 lbs with tank weight

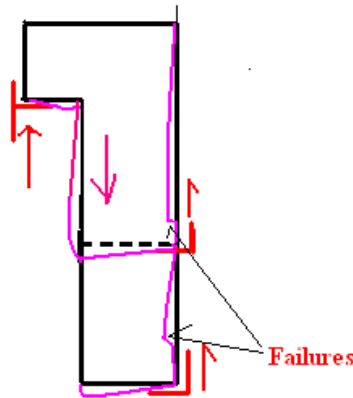

Saddle support and bottom support only on rear of tank creates a stress riser when the weight of the tank causes the PPL to sag under the load. Epoxy/glass secures the tank so firmly that the bulge or bending sets up a stress riser in the tank wall and a crack. Autopsy of tank left unfilled where it could get brittle then refilled indicates failures at the points noted.

So how do we fix it?

For new installations:

You can go back to the original mounting considerations with a new build. If you prefer your tank to be permanently bonded, as in the manual, lay your tank in the inverted cockpit module with spacers as indicated, and glass the tank in. Then install the cockpit module in the fuselage and mark where the tank sits above the fuselage floor. Remove the cockpit module and mark where the tank edges are on the floor. Then place a cork liner about 1-2 inches wide on the bottom front and saddle area to mate to a floor support for the tank and prevent chafing. Once you have placed the cork on (use 5 minute to hold the cork in place), make a support on the fuselage floor for the tank to help prevent it from sagging. The support can be made by carving foam, however, you may find it quicker to make a thick solution of your expand cell, provided in your kit, that is shaped along the contour just

inside the lines you made on the fuselage floor, about 1.5 inches wide and tall enough for the tank to hit against and form a seal. Normally I do the inside and front sides only, and none on the outboard side. Lay plastic over the expand cell for release and drop the cockpit module back in and allow to cure. After cure, remove the cockpit module, note where the cork indented the expand cell and sand the expand cell down to the cork interface line on your expand cell. I cut out allow a channel at the intersection of the L shape for letting any fuel or air trapped from a leak to find its way down to the center so I can see where future leaks are coming from. Test fit your tank/cockpit module and make sure the tank is floating. I make sure a .040 spacer will go between the tank (with cork) and the expand cell support. I go one step further and put two layers of bid over the support for stiffness. Now the tank is secure, well supported and ready for cockpit module insertion. Later when the tank is fueled, the fuselage will support the tank front and center.

For tanks already installed:

It is much more difficult to add support, but it can be done. The fastest way to add forward and side tank support is to use polyurethane spray insulation foam to inject under the tank. **Do not use expansion foam**, use only single expansion. This foam flows in and fills the gap, sticks to everything, but does not expand. What you see is what you get. After cure, sand the foam to make it neat. You may also make slivers of 8 pound polyurethane (brown foam) to shape and install for support. Again, I will poke a hole through the front and side mount corner to allow air to escape and any fuel leaks later to show up.

In the US I have done the following to my aircraft. To prevent chafing of the glass to tank, I use old fashioned cork that is 1/8 inch thick at all the support points. So the front ledge, saddle and all around the bottom of the tank will get a layer of 1/8 inch thin foam. Cover the areas of the tank which will have glass supports with release plastic, not tape. Note that I have about 5/8 inch space between the top of the tank and the cockpit module. This allows installation of fuel level probes, sight gauge lines, etc. We will remove the plastic by pulling out the 5/8 inch spacer and dropping the tank a bit and removing the plastic. Once the plastic is out, and the support glassing inspected, put the spacers back in and check the cork to glass contact. If all is well, then follow the procedure above to make under tank supports. Install the cockpit module and then move the tank by hand to check security. We don't want the tank to bounce around in the aircraft. Make up small glass strips to secure the tank to the fuselage and cockpit module. Two on each side of the tunnel about 2 inches wide, two on the front side and two on the top bracket. Or you may use polyurethane foam and 5 minute epoxy to hold the tank secure and forgo the tapes.

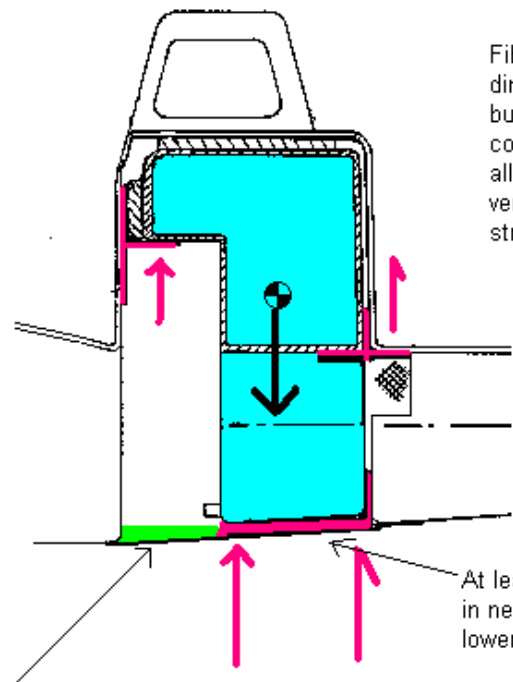

Fiberglass supports are not glued directly to tank, only to the bulkhead. Use cork padding and cover tank with release tape to allow the tank supports give vertical support without bending stress.

At least support the tank which is in near proximity contact with the lower fuselage skin

Possible extension to add a longeron from front face to rear of tank.