

[CLICK HERE TO LEARN MORE](#)

Static

Pitot



- J25 Unswitched Audio Out Pin 18 - J1 Pin44 PMA9000EX
- J25 Unswitched Audio Grd Pin16 - J1 Pin43 PMA9000EX
- J9 RS232 #4 Out Pin 1 - J25 Pin22 ARINC Serial In
- ← J9 RS232 #4 In Pin 6 - J25 Pin10 ARINC Serial Out
- J9 RS232 #4 Grd Pin 5 - J25 Pin9 ARINC Serial Grd
- J25 RS232 #3 Out Pin 4 - Pin4 SL30 Serial In
- ← J25 RS232 #3 In Pin 5 - Pin5 SL30 Serial Out
- J25 RS232 #1 Out Pin 10 - P1001 Pin27 GTN650 GPS RS232 In
- ← J25 RS232 #1 In Pin 22 - P1001 Pin8 GTN650 GPS RS232 Out
- J25 RS232 #2 Out Pin 13 - Pin7 ADS600-B Alt Enc Serial In
- Pin10 GTX327 Alt Enc Serial In
- J25 RS232 Serial 2/3 Grd Pin 21 - Pin6 ADS600-B Alt Enc Serial Grd
- Pin3 SL30 Serial Grd
- Pin13 GTX327 Alt Enc Serial Grd
- Ground Pin 3
- +12 VDC Pin 1 - J4Pin4 VP200



- ← J9 RS232 #4 In _____ - Pin7 CO Guardian Serial Out
Pin 6
- _____ J9 RS232 #4 Grd _____ - Pin3 CO Guardian Serial Grd
Pin 5
- _____ J25 RS232 #3 Out _____ → - Pin24 ADS600-B Serial In
Pin 4
- ← J25 RS232 #3 In _____ - Pin5 ADS600-B Serial Out
Pin 5
- ← J25 RS232 #1 In _____ - GPSMap 496 Blue wire
Pin 22
- ← J25 RS232 #2 In _____ - J3Pin20 VP200 Serial Out
Pin 25
- _____ J25 RS232 #2 Out _____ → - J3Pin21 VP200 Serial In
Pin 13
- _____ J25 RS232 Serial 2/3 Grd _____ - J3Pin10 VP200 Serial Grd
Pin 21 - Pin23 ADS600-B Serial Grd
- _____ Ground
Pin 3
- _____ +12 VDC
Pin 1 _____ - J6Pin3 VP200

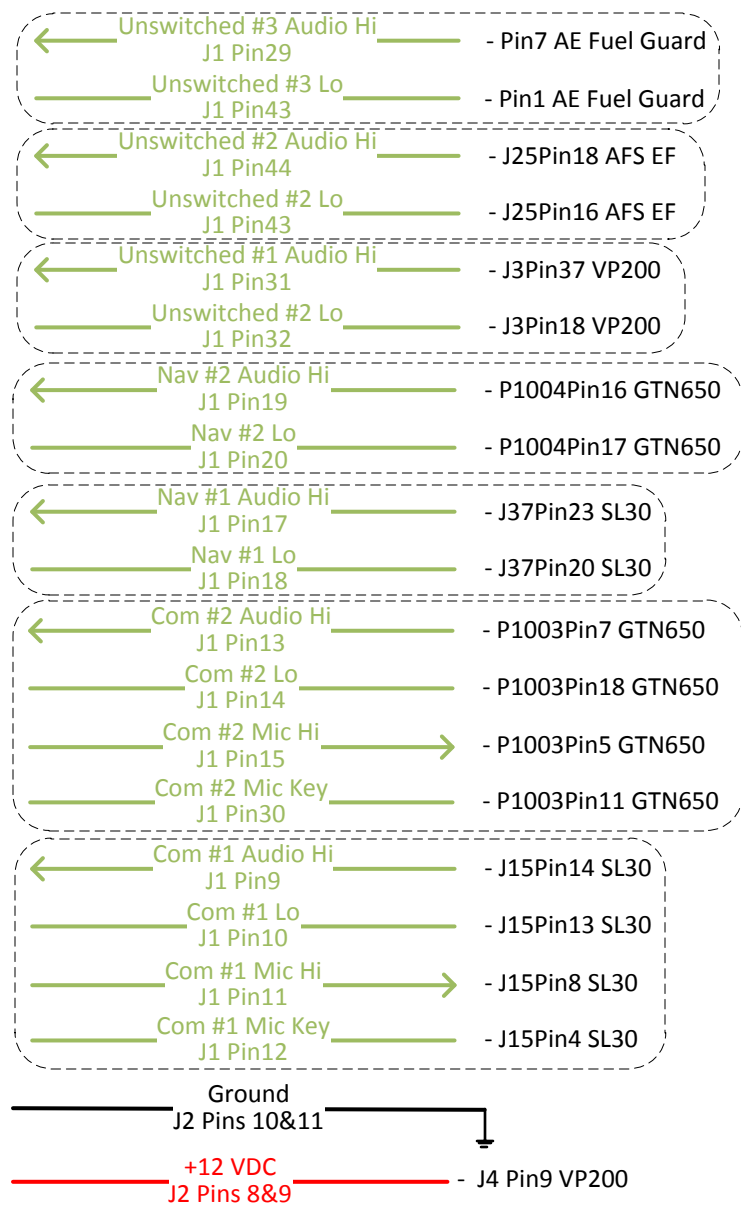
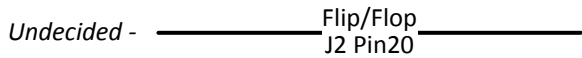
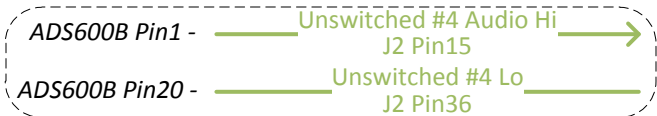

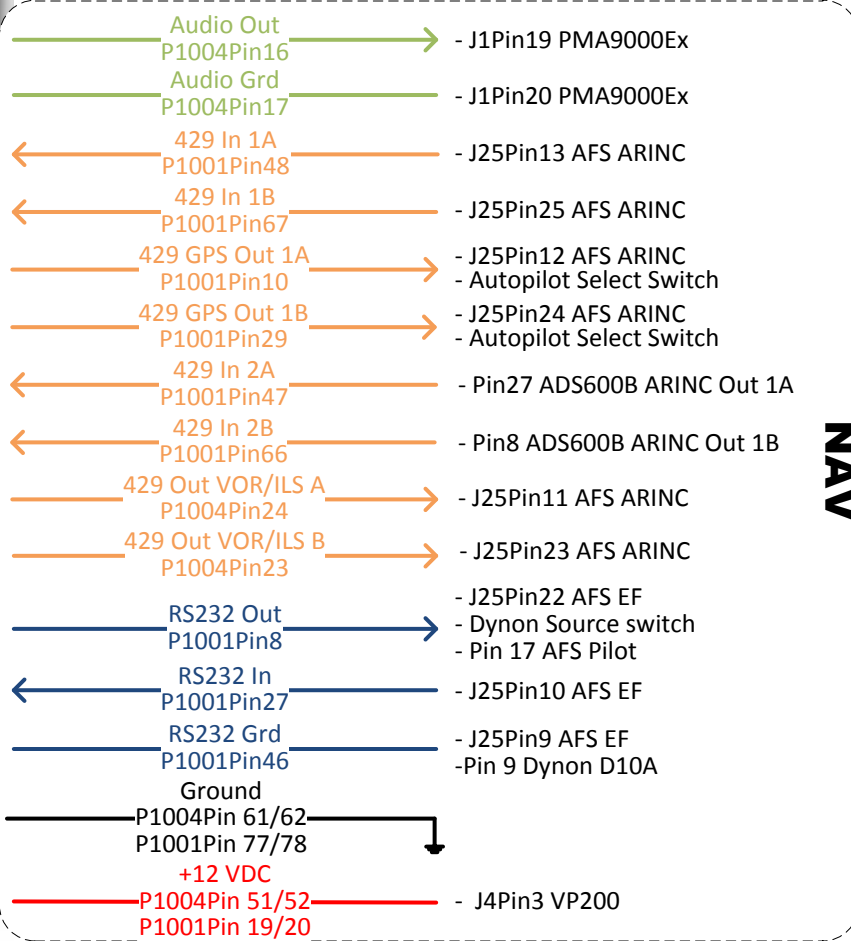
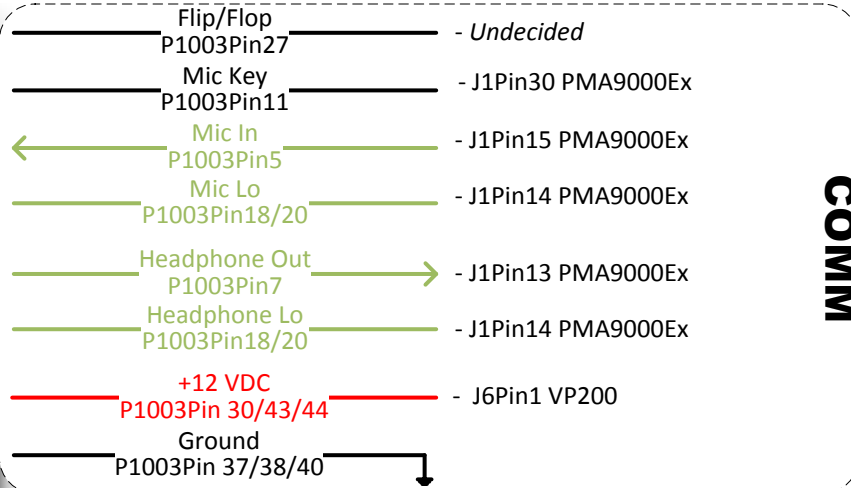

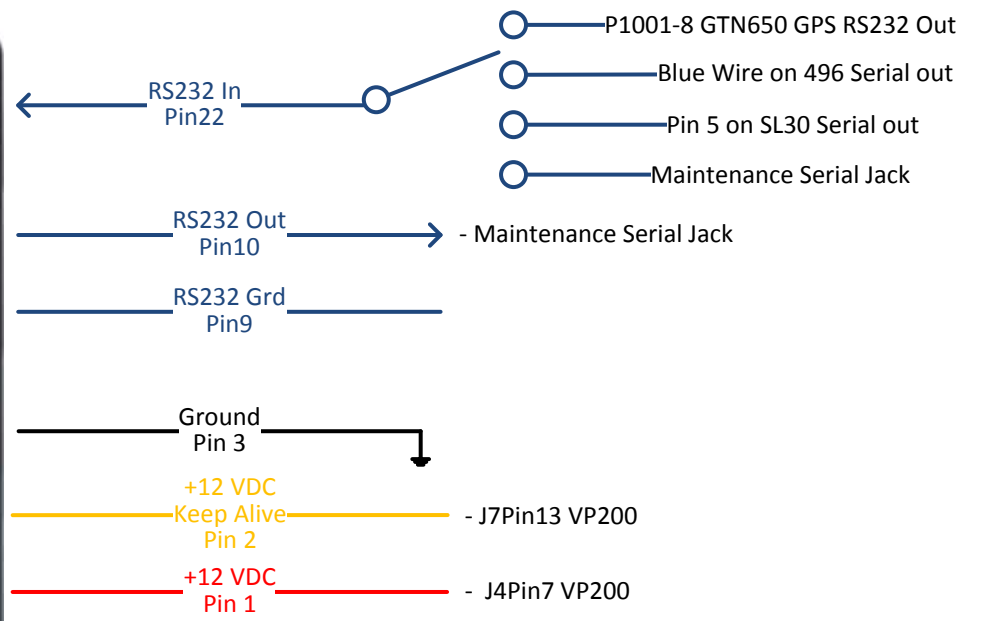

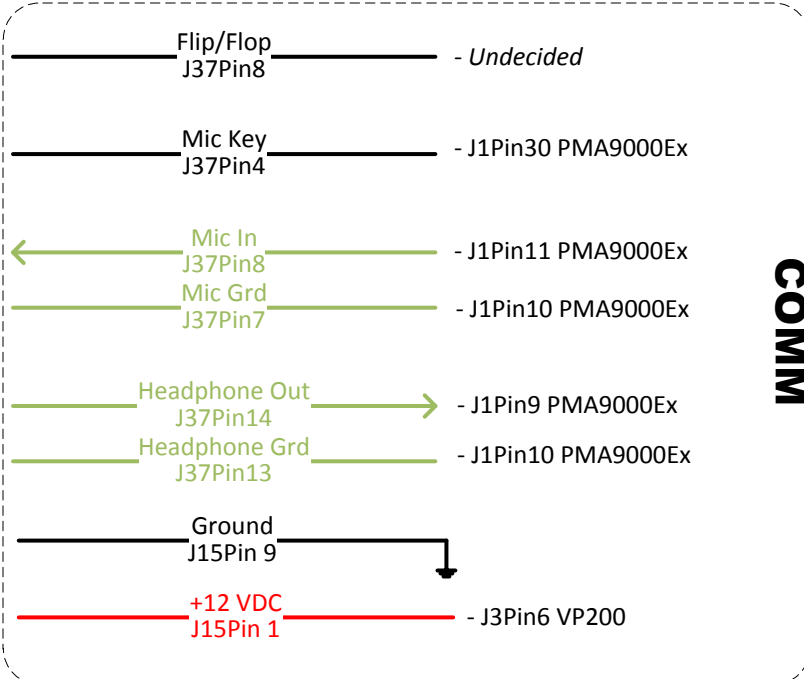
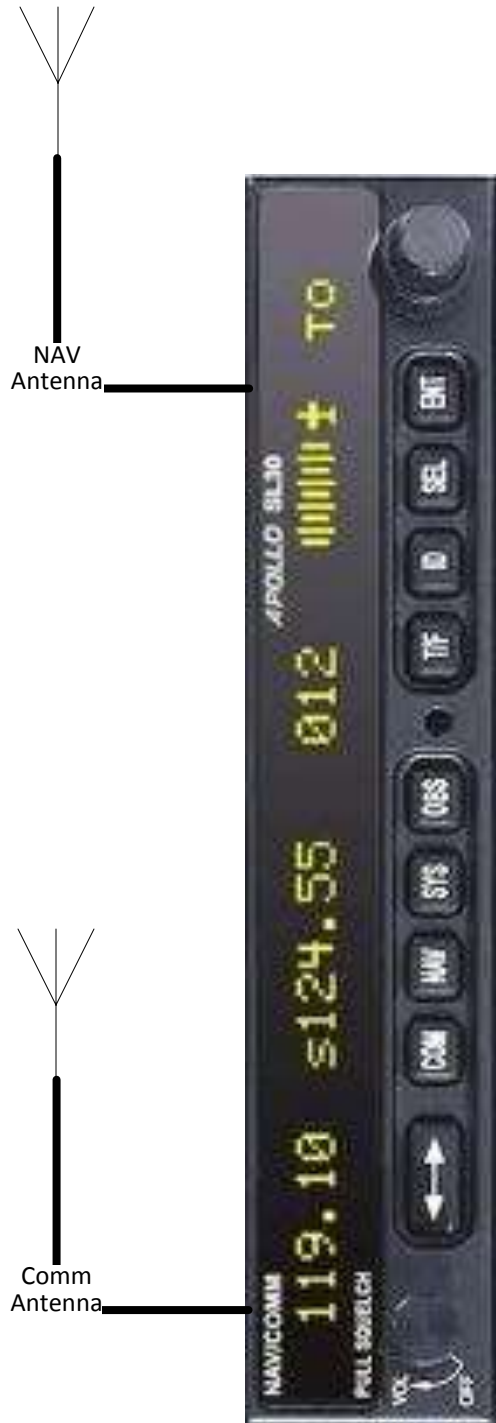

COMM

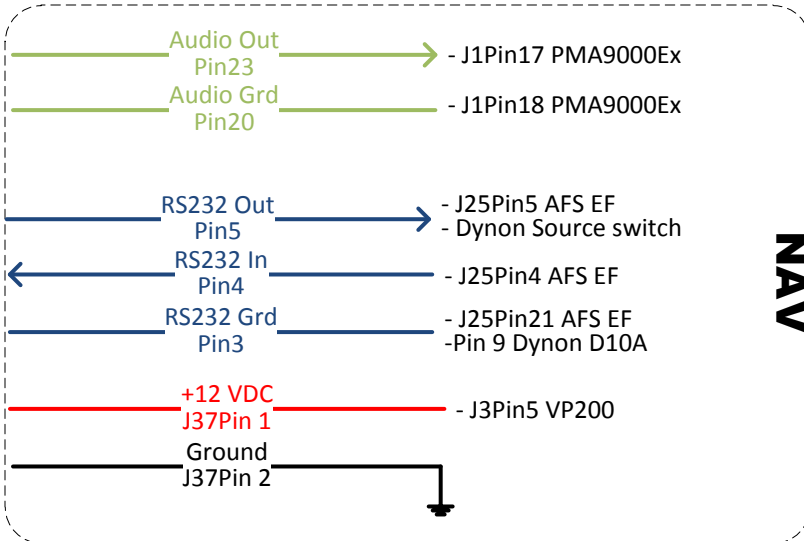

NAV

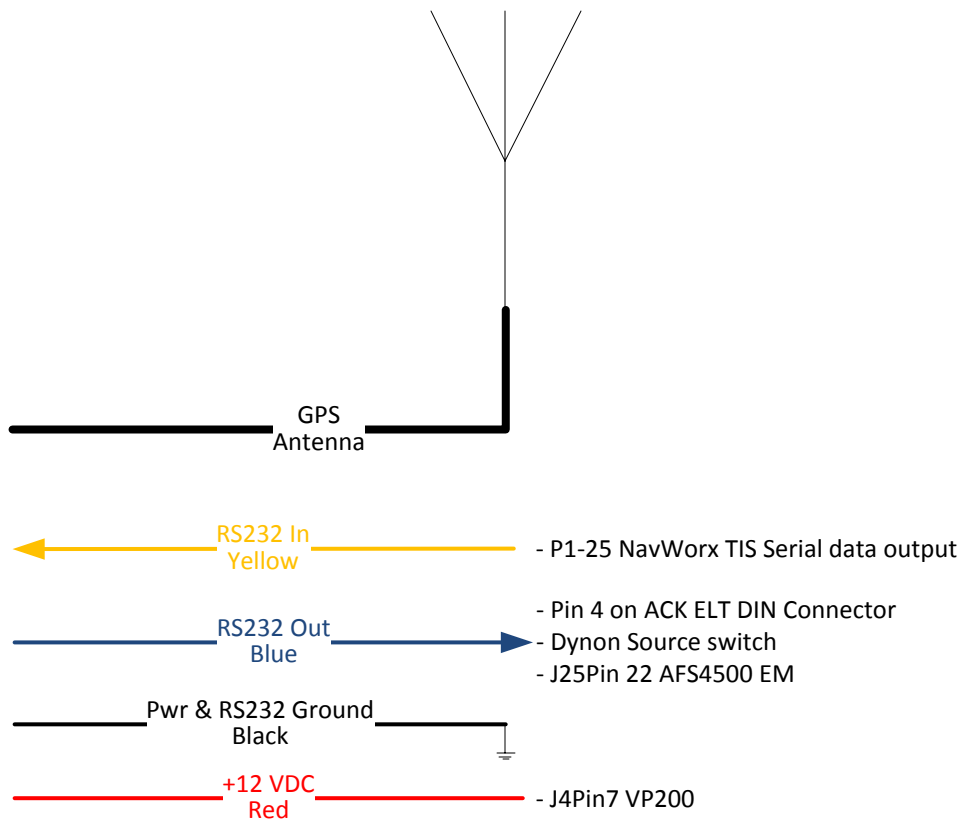

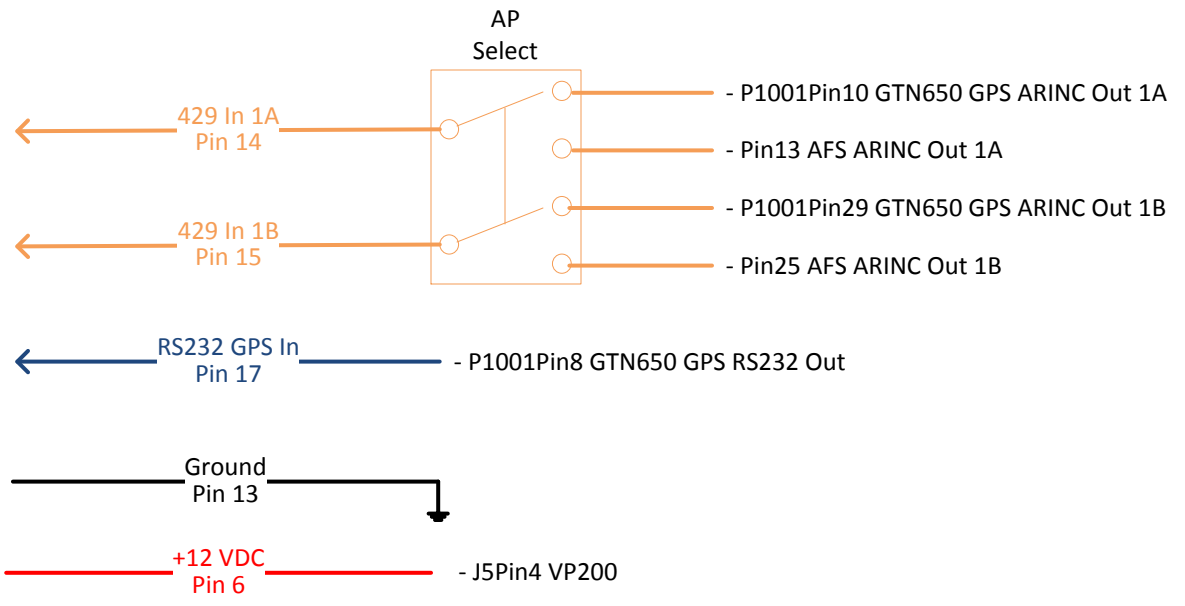

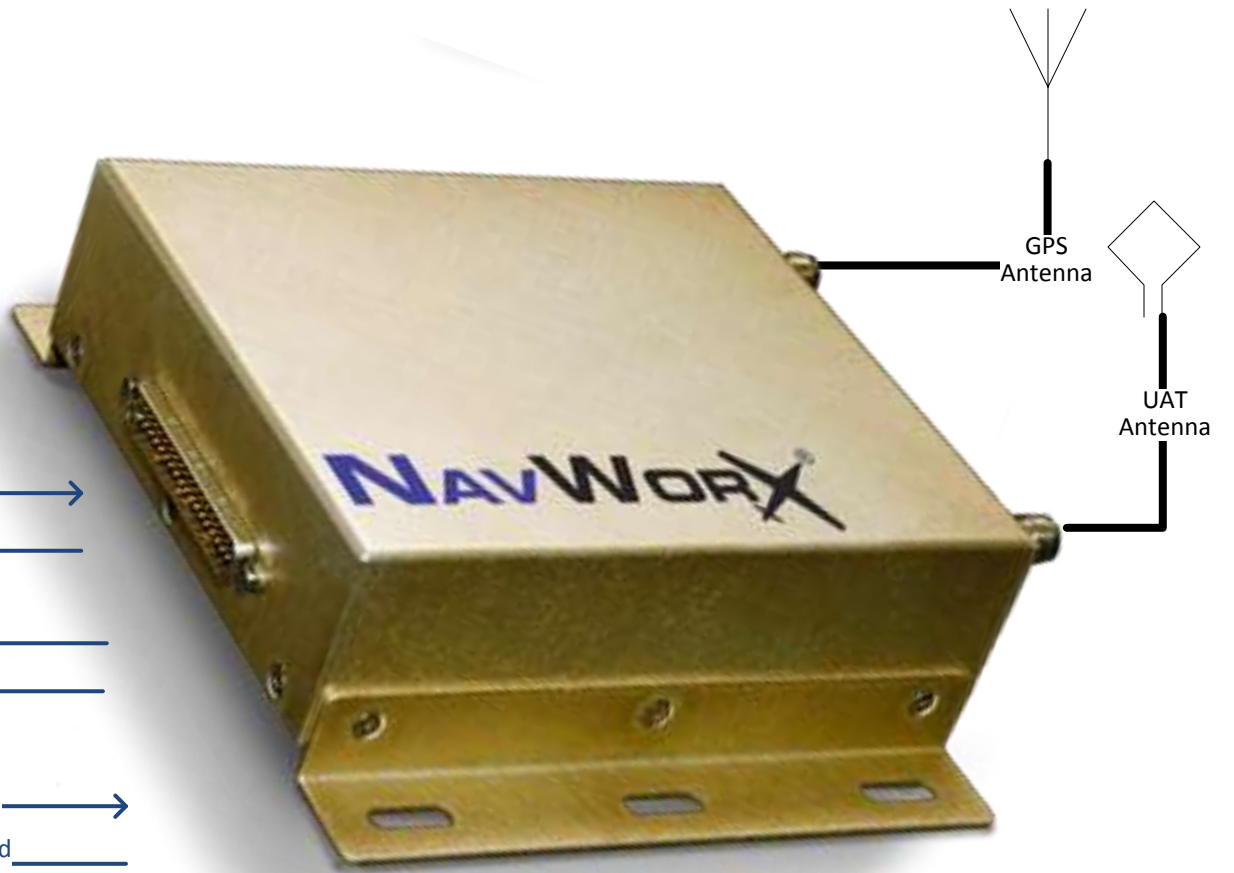
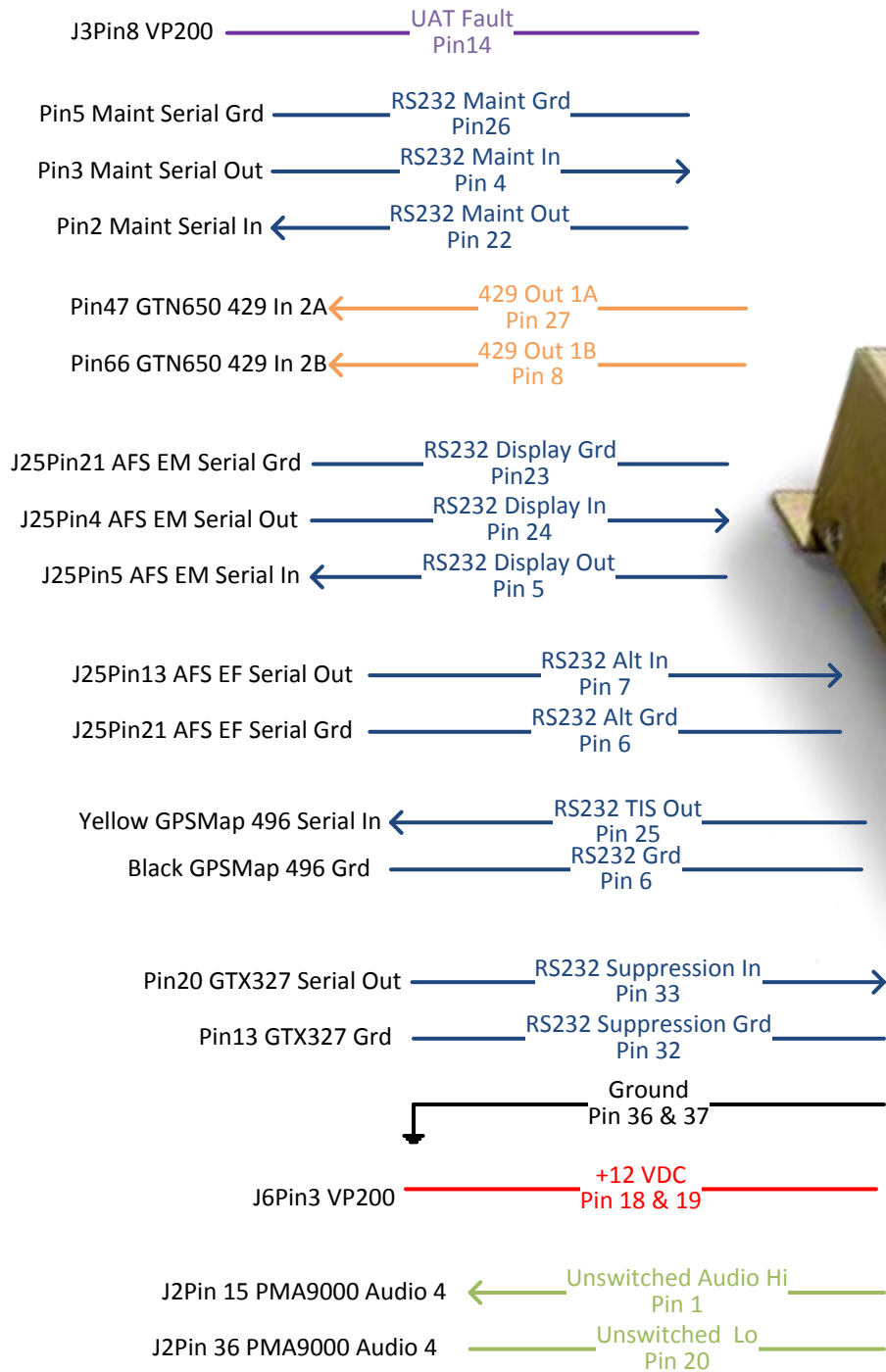

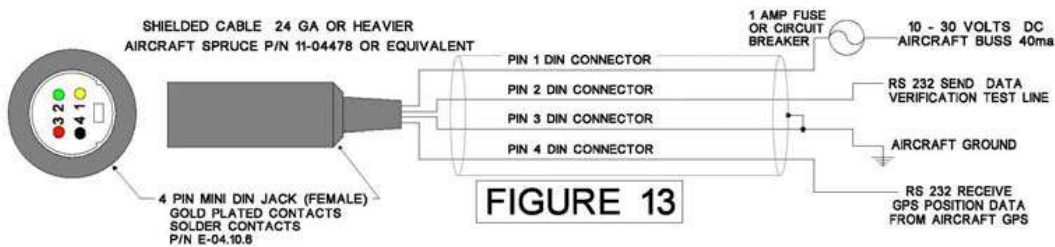
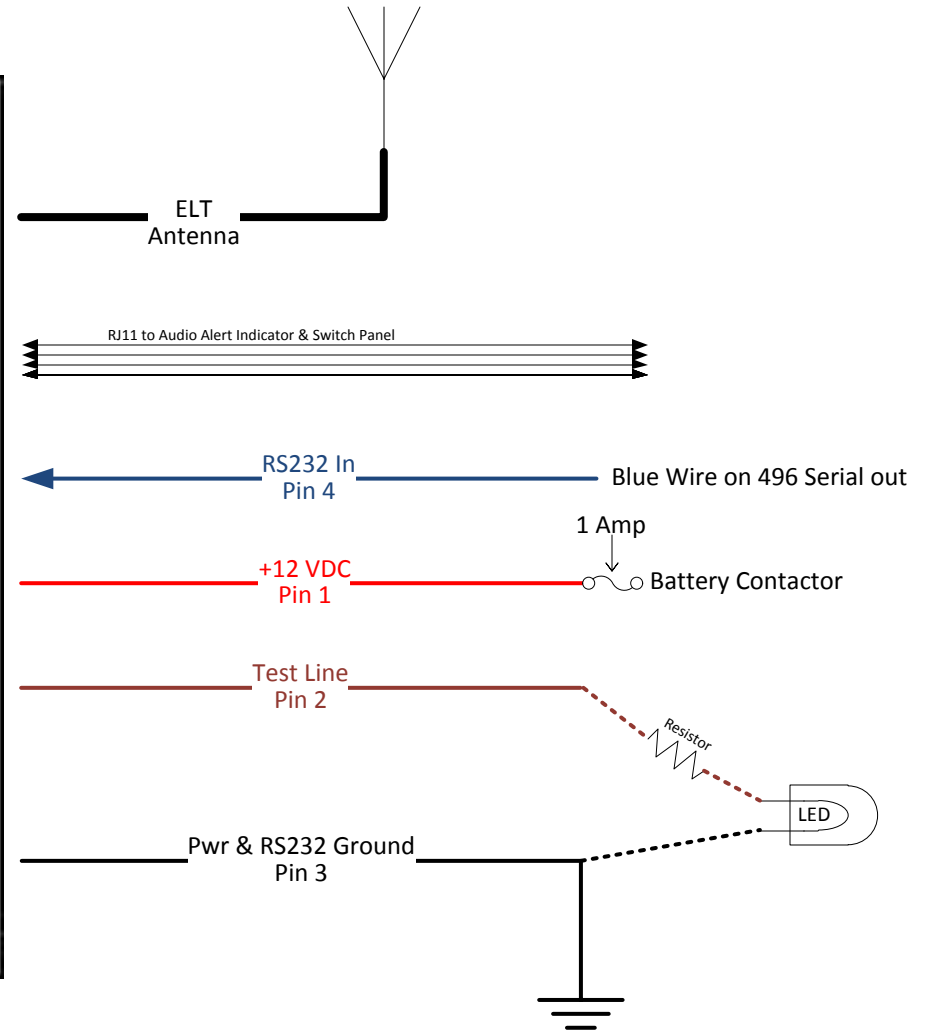

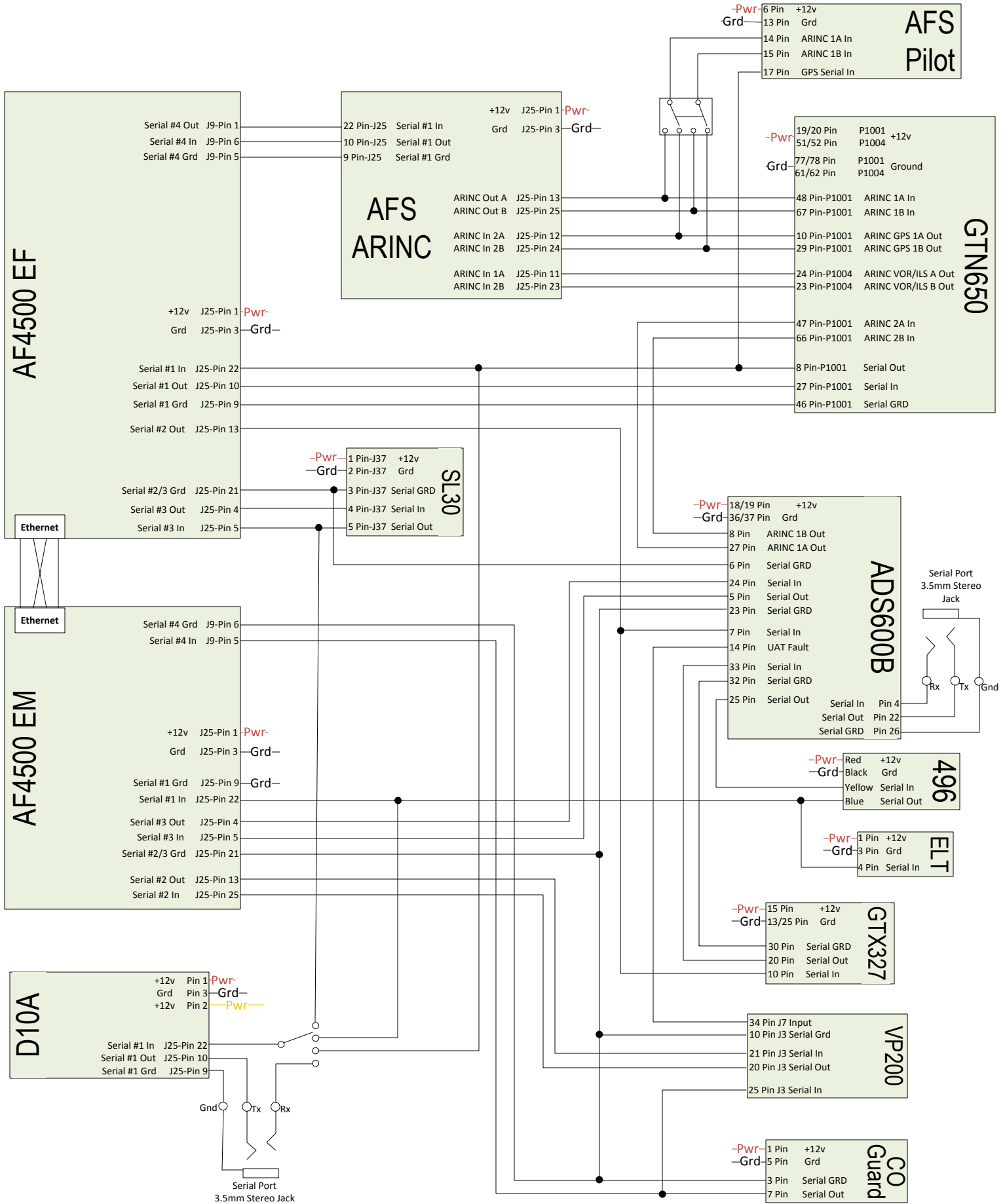

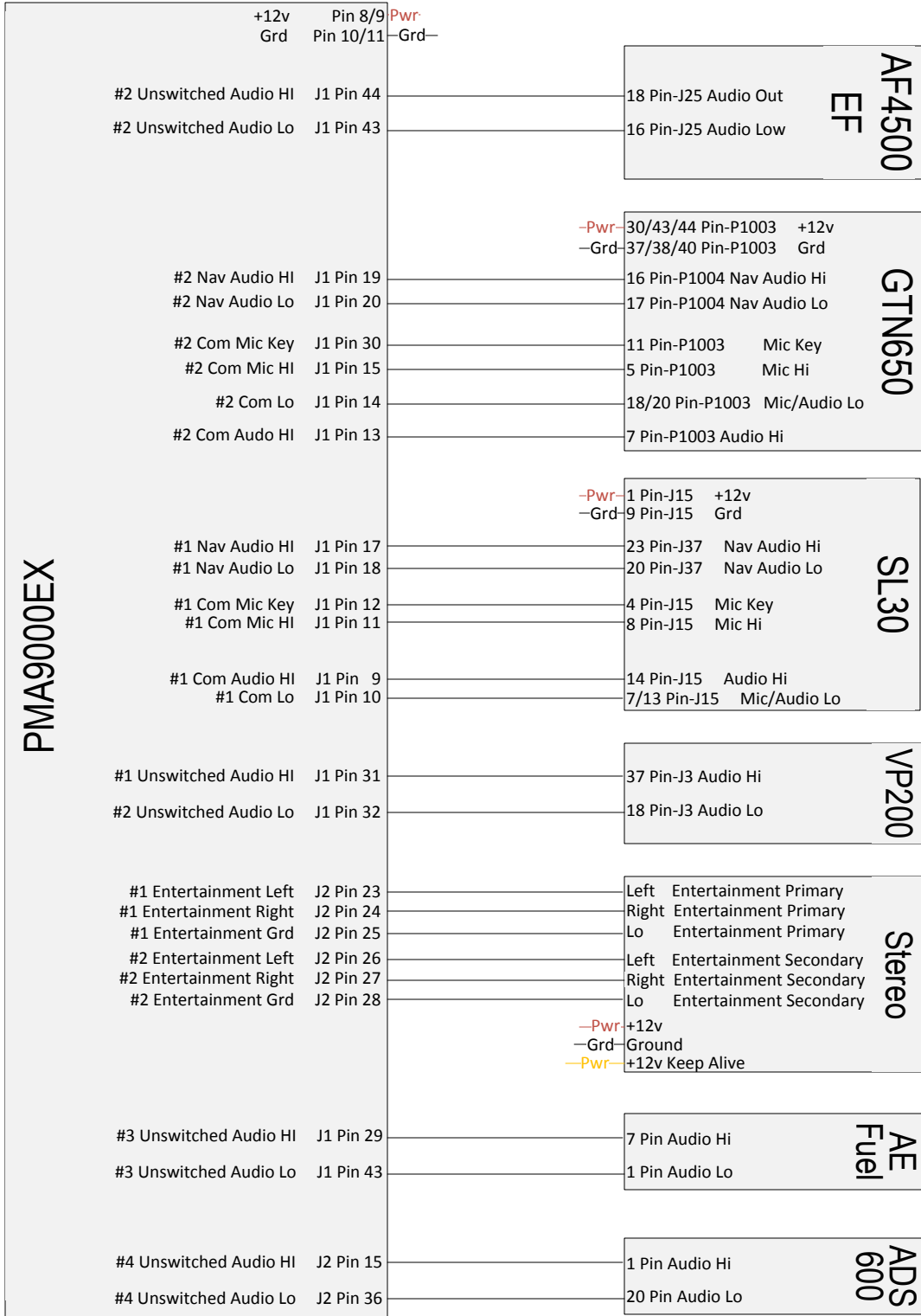

L Fuel Low	Master Warn	CO Detect	R Fuel Low
------------	-------------	-----------	------------

Serial Port
3.5mm Stereo Jack

