

Magneto connexions:
Route separately from other wiring
(Ground screens both ends)

Important: engine-related wiring must comply with Rotax installation manual

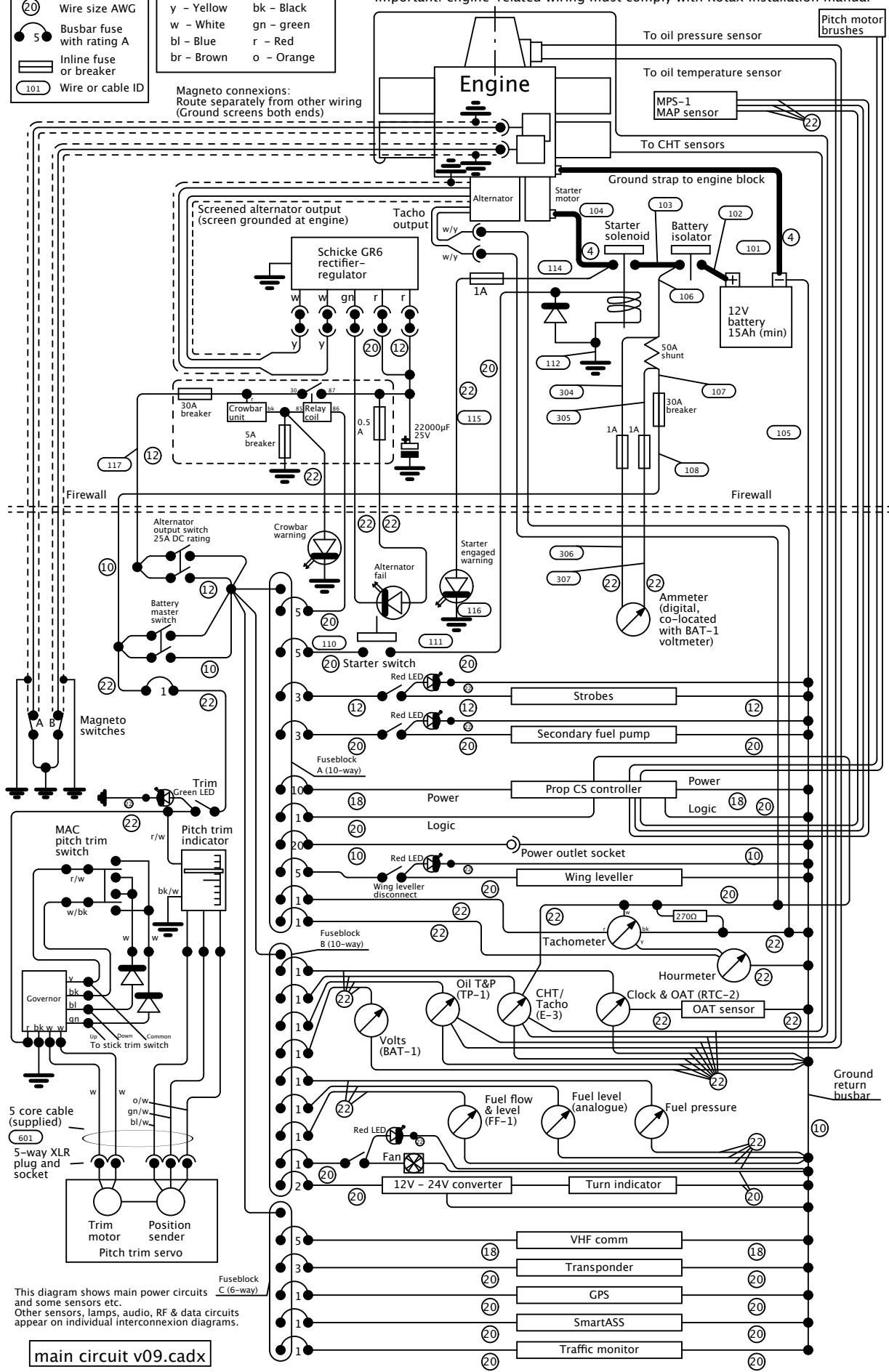

This diagram shows main power circuits and some sensors etc. Other sensors, lamps, audio, RF & data circuits appear on individual interconnexion diagrams.

main circuit v09.cadx