

MAGNETIC SENSOR

MP1005–MP1007 Series



Solid state, magnetic position sensors in adjustable, threaded housing.

Features

- Excellent output stability over operating temperature range
- Regulated power supply not required
- Reverse battery protection to -24VDC
- Meets IEC529 IP67 for dust and water protection
- Wire: 20 AWG, tin plated, polyolefin insulation
- Anodized aluminum housing
- South pole activated
- RoHS Compliant

- Open Collector (NPN) output can be used with bipolar or cmos logic circuits with suitable pull up resistor
 - Output switches low (off) when the magnetic field at the sensor exceeds the operate point threshold
 - Output switches high (on) when the magnetic field is reduced to below the release point threshold

Applications

- Limit switch
- Home security
- Door position

Specifications

Part Number	Operating Voltage Range (VDC)	Supply Current (mA max.)	Output	Output Saturation Voltage (mV max.)	Output Current (mA max.)	Operating Temp Range (°C)	Storage Temp Range (°C)	Operate Point Gauss (max.)	Release Point Gauss (min.)	Housing Color	Wires
MP100502	4.75 – 24	12	3-wire sink	700	25	-40 to 125	-40 to 125	300	60	Red	20 AWG x 1m BBB
MP100701	4.75 – 24	16	3-wire sink	700	25	-40 to 105	-40 to 125	300	60	Black	20 AWG x 1m BBB

Notes: These sensors require the use of an external pull-up resistor, the value of which is dependent on the supply voltage. See page 22 for recommendations. Pull-up resistor should be connected between output (Black) and Vcc (Brown).

Dimensions inches (mm)

All tolerances ± 0.005 (0.13) unless otherwise noted.

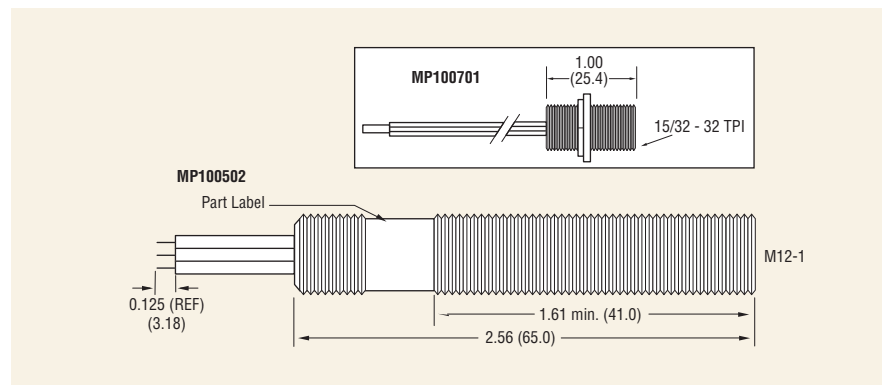

Open Collector Sinking Block Diagram

