

Title: IVO In-Flight Adjustable Propeller Automatic Over-Current Limiter		Rev: A
Sheet 1: Schematic		Size: 11x8.5
Date: 08 July 2017	Drawn by: EP	
Sheet: 1 of 3		

An open source project of the AeroElectric-List forum.
 Based on an idea by Doug (kfav8r).
 Circuit by Robert L. Nuckolls III.
 PIC code by Paul A. Fisher.
 CAD/PCB by Eric D. Page.

A

A

D
C
B

D
C
B

6

5

4

3

2

1

6

5

4

3

2

1

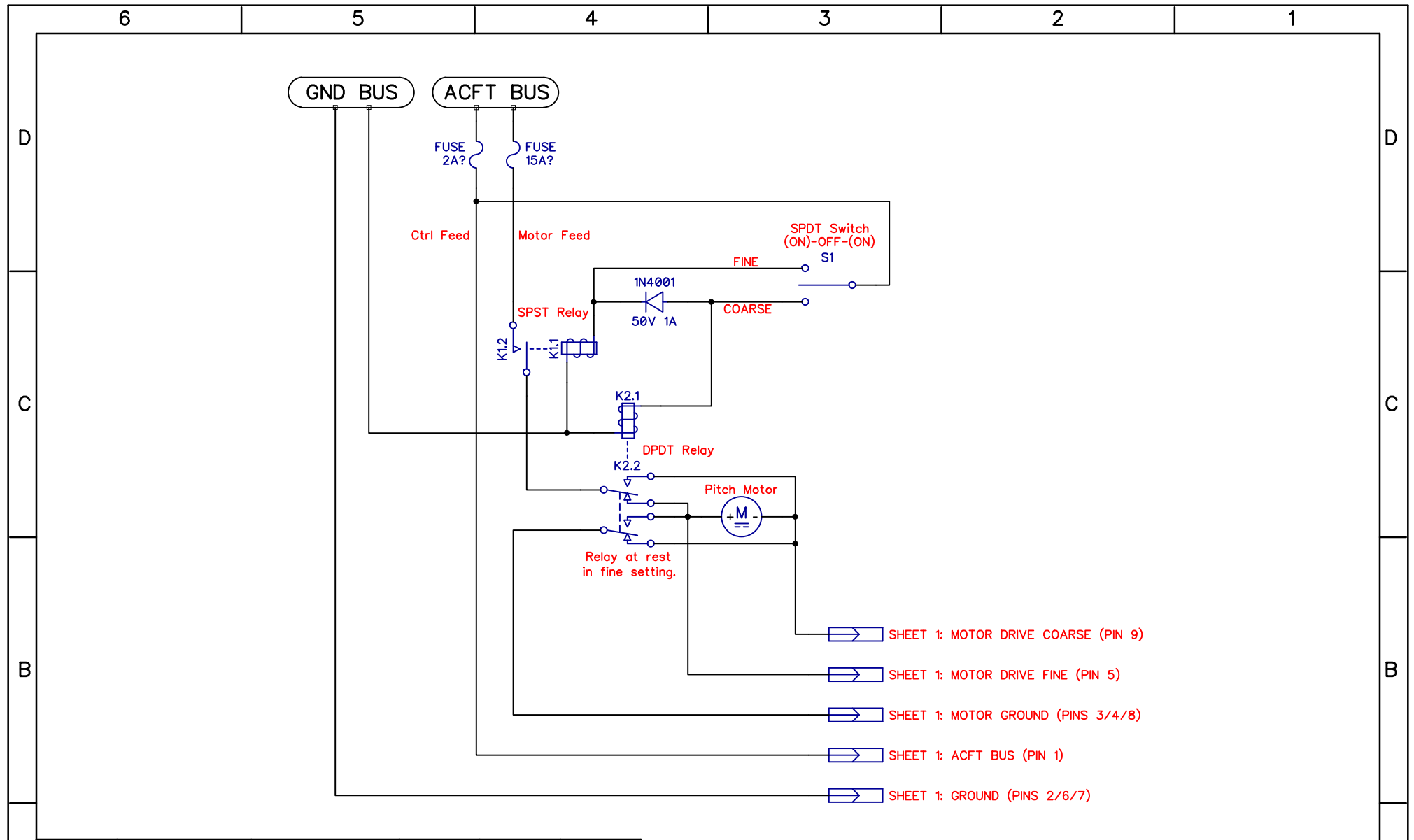

Title: IVO In-Flight Adjustable Propeller Automatic Over-Current Limiter		Rev: A
Sheet 2: Wiring Diagram		Size: 11x8.5
Date: 08 July 2017	Drawn by: EP	
Sheet: 2	of 3	

An open source project of the AeroElectric-List forum.
 Based on an idea by Doug (kfav8r).
 Circuit by Robert L. Nuckolls III.
 PIC code by Paul A. Fisher.
 CAD/PCB by Eric D. Page.

A

A

D
C
B

D
C
B

6

5

4

3

2

1

6

5

4

3

2

1

6

5

4

3

2

1

D

D

BILL OF MATERIALS (PCB):

C1: TDK Corporation FG16X7R1E106KRT06 10uF 25V X7R Ceramic Capacitor
 C2-C3: Vishay BC Components K104K15X7RF53L2 0.1uF 50V X7R Ceramic Capacitor
 D1-D2: Comchip Technology 1N4001-G 50V 1A Rectifier Diode DO-41
 D3: Fairchild/ON Semiconductor 1N5231B 5.1V 500mW Zener Diode DO-35
 J1: DB-9 (P/N TBD)
 Q1: Fairchild/ON Semiconductor 2N7000 N-Ch MOSFET 60V 200mA TO-92-3
 Q2: Fairchild/ON Semiconductor PN2222ATFR NPN BJT 40V 1A TO-92-3
 Q3: Infineon Technologies IRLB8314PBF N-Ch MOSFET 30V 184A TO-220-3
 R1-R8: Stackpole Electronics RNF14FTD2K00 2k-Ohm 1/4W 1% Axial Resistor
 R9-R11: Stackpole Electronics WW3FTR200 0.2-Ohm 3W 1% Axial Resistor
 U1: Fairchild/ON Semiconductor LM431CCZ Adjustable VRef Shunt TO-92-3
 U2: Microchip PIC12F683-E/P 8-BIT MCU DIP-8

C

C

B

B

Title:

IVO In-Flight Adjustable Propeller
Automatic Over-Current Limiter

Rev:

A

Size:

11x8.5

Sheet 3: Bill of Materials

An open source project of the AeroElectric-List forum.
 Based on an idea by Doug (kfav8r).
 Circuit by Robert L. Nuckolls III.
 PIC code by Paul A. Fisher.
 CAD/PCB by Eric D. Page.

A

A

Date:

08 July 2017

Drawn by: EP

Sheet: 3 of 3

6

5

4

3

2

1