

From batteries
(Drawing 4)

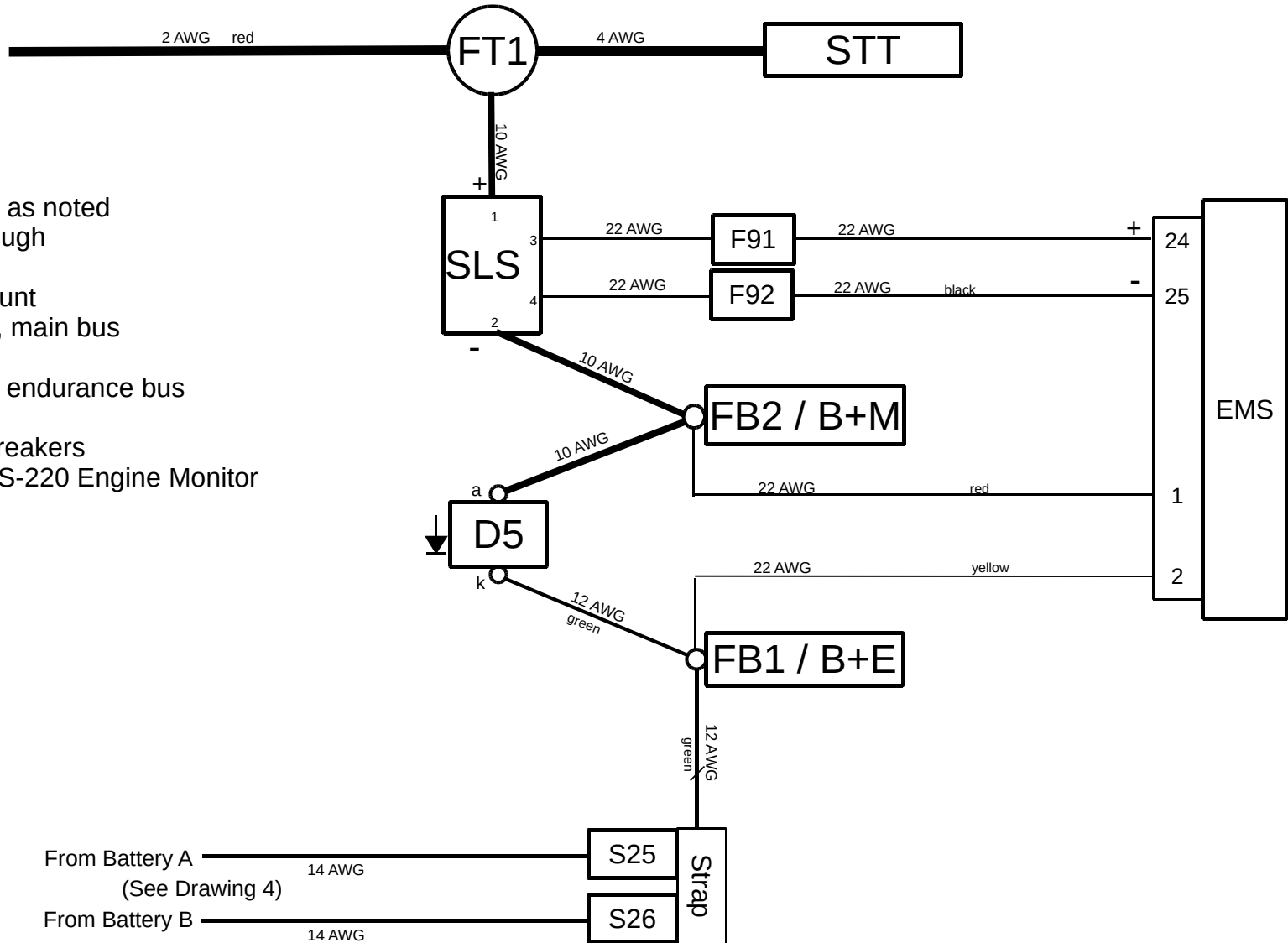

All wires are red except as noted

FT1 – Firewall passthrough

STT – Engine starter

SLS – System Load Shunt

FB2/B+M – Fuse Block, main bus

D5 – Diode

FB1/B+E – Fuse Block, endurance bus

F91/F92 – 1a fuses

S25/S26 – 10a switchbreakers

EMS – Skyview SV-EMS-220 Engine Monitor

Note: All wires are white unless noted otherwise

GlaStar N51DW		2
Power Distribution	Modified	24 Oct 2020
	Created	17 Mar 2018
	Drawn By	Doug Windhorn