

Model SL40 VHF COMM Transceiver Installation Manual

June 2008
560-0956-03 Rev C



© 2004-2008 Garmin Ltd. or its subsidiaries. All rights reserved. Printed in the U.S.A.

Garmin International, Inc., 1200 East 151st Street, Olathe Kansas 66062, U.S.A. Tel:
913/397.8200, 888/606.5482

Garmin (Europe) Ltd., Liberty House, Bull Copse Road, Hounslow Business Park,
Southampton, SO40 9RB, UK, Telephone: +44 (0) 870 850 1243

Garmin AT, Inc., 2345 Turner Road, S.E., Salem, OR 97302, U.S.A. Tel: 800/581.8101
Fax: 503/364.2138 Canada Tel: 800/654.3415 International Tel: 503/391.3411

Cage Code: 0XCJ6

Visit our web pages at <http://www.garmin.com>

Send comments about this manual by email to: techpubs.salem@garmin.com

Except as expressly provided herein, no part of this manual may be reproduced, copied, transmitted, disseminated, downloaded or stored in any storage medium, for any purpose without the express written permission of Garmin. Garmin hereby grants permission to download a single copy of this manual and of any revision to this manual onto a hard drive or other electronic storage medium to be viewed for personal use, provided that such electronic or printed copy of this manual or revision must contain the complete text of this copyright notice and provided further that any unauthorized commercial distribution of this manual or any revision hereto is strictly prohibited.

Information in this document is subject to change without notice. Garmin reserves the right to change or improve their products and to make changes in the content of this material without obligation to notify any person or organization of such changes or improvements.

Garmin™, Garmin AT™, and GNS are trademarks of Garmin Ltd. or its subsidiaries. These trademarks may not be used without the express permission of Garmin.

HISTORY OF REVISIONS

Revision	Date	Description
--	12/18/96	Initial release.
00A	1/30/97	Modified selectivity value to 7 kHz.
-01	3/14/97	Change recommended coax from RG-58 to RG-142B
-02	6/26/98	New software version
-02a	9/22/99	Added new connector pins and crimping tools
-03	10/1/02	Updated ship kit information and changed II Morrow to Garmin AT.
-03a	9/15/03	Company name change
-03 B	4/12/40	Added license requirement comment and removed Apollo.
-03 C	6/19/08	Added ETSO information and updated logo.

IMPORTANT NOTE

“The conditions and tests required for TSO/ETSO approval of this article are minimum performance standards. It is the responsibility of those desiring to install this article on or within a specific type or class of aircraft to determine that the aircraft operating conditions are within TSO/ETSO standards. The article may be installed only if further evaluation by the user/installer documents an acceptable installation and is approved by the Administrator.”

Source: FAA TSO-C37d, TSO-C38d, and TSO-C128 and EASA ETSO-2C37e, ETSO-2C38e, and ETSO-2C128.

ORDERING INFORMATION

To receive additional copies of this publication, order part # **560-0956-03 Rev C**, *SL40 VHF COMM Installation Manual*.

NOTES

TABLE OF CONTENTS

SECTION 1 - INTRODUCTION	1
ABOUT THIS MANUAL	1
APOLLO SL40 DESCRIPTION	1
FEATURES	1
REGULATORY COMPLIANCE.....	2
UNPACKING THE EQUIPMENT.....	3
PACKAGE CONTENTS	3
OTHER REQUIRED MATERIALS.....	4
SPECIAL TOOLS REQUIRED.....	4
LICENSE REQUIREMENTS	4
SECTION 2 - INSTALLATION.....	5
PRE-INSTALLATION INFORMATION.....	5
INSTALLATION OVERVIEW	5
INSTALLATION CONSIDERATIONS.....	5
MOUNTING CONSIDERATIONS.....	5
MINIMUM SYSTEM CONFIGURATION.....	5
EQUIPMENT MOUNTING	5
ELECTRICAL CONNECTIONS	7
POWER.....	7
SPEAKER AND HEADPHONE OUTPUTS.....	7
MICROPHONE INPUTS.....	7
TRANSMIT KEY INPUT.....	7
INTERCOM SELECTOR SWITCH.....	7
SERIAL INTERFACE	8
ANTENNA INSTALLATION AND CONNECTIONS	8
POST INSTALLATION CHECKOUT.....	12
SECTION 3 - SPECIFICATIONS	15
ELECTRICAL	15
PHYSICAL.....	15
ENVIRONMENTAL.....	15
RECEIVER PERFORMANCE	16
TRANSMITTER PERFORMANCE	16
INTERCOM PERFORMANCE	17
CONTROL INPUTS.....	17
ANTENNA REQUIREMENTS.....	17
SERIAL INTERFACE.....	17
REAR CONNECTOR PINOUT	18
SECTION 4 - LIMITATIONS.....	19
INSTALLATION	19
OPERATIONAL.....	19
APPENDIX A - TROUBLESHOOTING.....	21
CONTACTING THE FACTORY FOR ASSISTANCE	21

APPENDIX B - PERIODIC MAINTENANCE23
EQUIPMENT CALIBRATION23
 REFERENCE OSCILLATOR23
CLEANING THE FRONT PANEL.....23
APPENDIX C - ENVIRONMENTAL QUALIFICATIONS.....25
APPENDIX E - SERIAL INTERFACE SPECIFICATIONS27
RS-232 INPUTS27
RS-232 OUTPUTS29

LIST OF TABLES

TABLE 1 PACKAGE CONTENTS3
TABLE 2 CONNECTOR PINOUT18
TABLE 3 TROUBLESHOOTING GUIDE.....21

LIST OF ILLUSTRATIONS

FIGURE 1 SL40 FRONT PANEL2
FIGURE 2 MOUNTING FRAME ASSEMBLY6
FIGURE 3 CABLE ROUTING.....6
FIGURE 4 COAX CONNECTOR ASSEMBLY.....9
FIGURE 5 SL40 STANDALONE WIRING DIAGRAM10
FIGURE 6 SL40 TYPICAL AUDIO PANEL CONNECTIONS11
FIGURE 7 UNIT DIMENSIONS16

SECTION 1 - INTRODUCTION

ABOUT THIS MANUAL

This manual describes the installation of the SL40 Comm. It is intended for use by persons certified by the Federal Aviation Administration (FAA) to install aircraft navigation devices. It includes installation and checkout procedures for the SL40 unit to standards described in FAA advisory circular AC 20-67B.

Section 1 Provides an **introduction** to the SL40 unit. TSO certification information is also included in this section.

Section 2 Includes **installation** and checkout procedures.

Section 3 Includes complete **specifications**.

Section 4 Includes **limitations** for the equipment and installation.

Appendix A Includes **troubleshooting** information.

Appendix B Includes **periodic maintenance** requirements.

Appendix C Includes the **environmental qualification form**.

Appendix E Includes **serial data specifications**.

SL40 DESCRIPTION

The SL40 is a 760 channel VHF Comm transceiver. It is one member of the slimline series, which includes the SL40 Comm, the SL50 GPS, and the SL60 GPS/Comm.

FEATURES

The features of the SL40 Comm include:

- 760 channels
- Frequency range of 118.000 to 136.975MHz
- Active and standby frequency display
- 16 character high-intensity alphanumeric LED display
- Automatic display intensity
- Back-lit buttons
- Transmit status indicator

- Frequency memory and recall functions

- from remote source
- eight last used
- eight user stored
- Weather channels
- Frequency monitor function
- Built-in intercom function
- Stuck mic time-out
- Two microphone inputs
- Internal non-volatile memory - no battery required
- Full range input supply voltage
- 12 watt audio amplifier

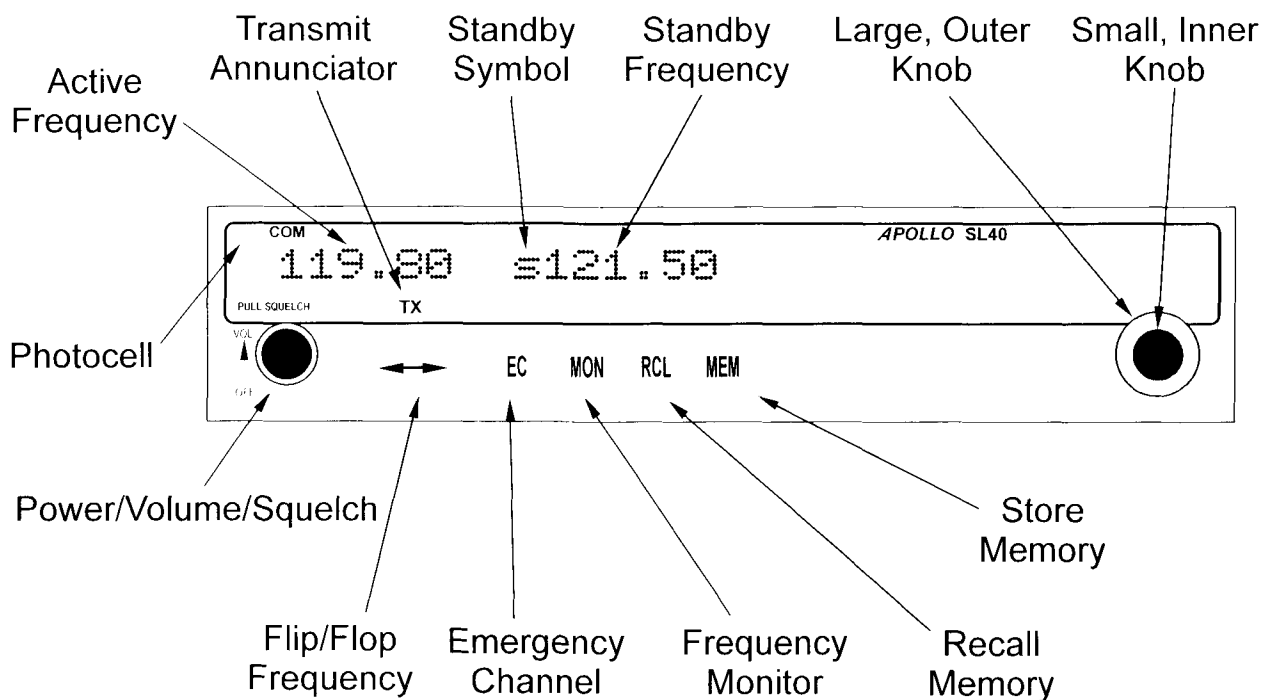

Figure 1 SL40 Front Panel

REGULATORY COMPLIANCE

The SL40 is designed and tested to meet the following TSOs and ETSOs:

Description	TSO	ETSO
Transmit	TSO-C37d	ETSO-2C37e
Receive	TSO-C38d	ETSO-2C38e
Unintentional Transmission (stuck mic)	TSO-C128	ETSO-2C128

The SL40 complies with the FCC requirements specified in:

CFR 47, Part 87, Aviation Services, Subpart D, Technical Requirements

CFR 47, Part 15, Radio Frequency Devices, Subpart B, Unintentional Radiators

The SL40 software is designed and tested to RTCA/DO-178B/ED128, level C.

The SL40 meets the additional standards as detailed in the Declaration of Conformity included on page 31.

Note: Unauthorized changes or modifications to the SL40 may void the compliance to required regulatory agencies and authorization for continued equipment usage.

UNPACKING THE EQUIPMENT

Carefully unpack the equipment. Visually inspect the package contents for any evidence of shipping damage. Retain all shipping containers and packaging material in case reshipment is necessary.

PACKAGE CONTENTS

As shipped from the Garmin AT, Inc. factory, the SL40 package includes most necessary items for installation other than supplies normally available at the installation shop, such as wire and cable ties, and required input and output equipment. The items included in the package are listed in Table 1.

Table 1 Package Contents		
Part #	Description	Qty
Comm unit		
430-6040-2xx	SL40 Comm Transceiver	1
SL40 Installation Kit, Part # 424-2006-2xx		
162-0100 or 162-1575	15 pin dsub connector shell	1
162-1008	Right angle coax plug	1
202-0001	Cable tie	2
204-2100	Shoulder bushing	2
221-0400	4-40 x 1/4 SS pan head Phillips machine screw with lock washer	4
224-0404	4-40 x 1/4 SS flat head Phillips machine screw	6
245-0022 or 245-0027	Crimp contact for dsub, 20 to 24 awg wire	15
310-5181-01	Mounting frame	1
310-5187-01	Connector mounting plate	1
998-0048	3/32 hex driver	1
204-0037	Edge grommet	6"
SL40 Manual Kit, Part # 564-0064-2xx		
560-0954-xx	SL40 User's manual	1
560-0956-xx	SL40 Installation manual	1

OTHER REQUIRED MATERIALS

The SL40 is intended for use with standard aviation accessories. The following items are required for the installation:

- comm antenna with cables
- a microphone
- a speaker or headphone

These items may be installed dedicated to the SL40 comm or by connections to an audio panel.

SPECIAL TOOLS REQUIRED

Crimp Tool

A crimp tool meeting MIL specification M22520/1-01 and a positioner/locator are required to ensure consistent, reliable crimp contact connections for the rear d-sub connectors. These tools are available from:

For pin p/n 245-0022

Astro Tool Corp.
21615 SW TV Highway
Beaverton, OR 97006

Phone (503) 642-9853
Fax (503) 591-7766

Crimp tool:
Positioner:

Astro Tool part #615708
Astro Tool part #616356

For pin p/n 245-0027

ITT Cannon
1851 E. Deere Ave.
Santa Ana, CA 92705-6500

Phone (714) 261-5300
Fax (714) 575-8324

Insertion tool:	ITT part # 274-7006-000 (Desc. CIET-20HD)
Regular duty Crimp tool:	ITT part #995-0001-585 (Desc. M22520/1-01)
Regular duty Locator tool:	ITT part #995-0001-244 (Desc. TH25)
Heavy duty Crimp tool:	ITT part #995-0001-584 (Desc. M22520/2-01)
Heavy duty Locator tool:	ITT part #995-0001-604 (Desc. M22520/2-08)

LICENSE REQUIREMENTS

An aircraft radio station license is required for operation of the transmitter once installed in the aircraft. An application must be submitted on FCC Form 404, which may be obtained from the FCC in Washington, DC, or any of its field offices. Procedures for applications are in CFR 47, Part 87, Aviation Services, Subpart B, Applications and Licenses. For aircraft not registered in the United States, please follow your local procedures.

SECTION 2 - INSTALLATION

This section describes the installation of the SL40 including mounting, wiring, and connections. A post installation check-out procedure is included at the end of this section.

PRE-INSTALLATION INFORMATION

Always follow good avionics installation practices per FAA Advisory Circulars (AC) 43.13-1A, 43.13-2A, and AC 20-67B, or later FAA approved revisions of these documents.

Follow the installation procedure in this section as it is presented for a successful installation. Read the entire section before beginning the procedure. Perform the post installation check-out before closing the work area in case problems occur.

INSTALLATION OVERVIEW

A successful installation should start with careful planning including determination of mounting location for the SL40, antenna mounting, connections to microphones, speakers, and headphones, cable routing, and other required modifications. Once the mounting location has been determined, prepare the mounting frame for installation. It may be easier to complete the wiring harness and attach the connectors to the mounting frame before installing the mounting frame.

INSTALLATION CONSIDERATIONS

MOUNTING CONSIDERATIONS

The SL40 is designed to mount in the avionics stack in the aircraft instrument panel within easy view and reach of the pilot. The standard package includes a mounting frame for ease of mounting, connections, and service of the unit. Allow an additional one inch clearance to the rear of the mounting frame for connectors and cables.

For typical installations, the SL40 does not require external cooling. When mounting the SL40, leave a clearance of 1/8 to 1/4 inch between avionics to allow for circulation.

MINIMUM SYSTEM CONFIGURATION

The SL40 requires connections to the following equipment as a minimum:

- power input
- speaker or headphone output
- microphone input
- an antenna

EQUIPMENT MOUNTING

Once the cable assemblies have been made, attach the 15 pin dsub and coaxial cable connectors to the rear connector mounting plate and the mounting frame as illustrated in Figure 2 and Figure 3. Route the wiring bundle as appropriate. The rear connector plate should be attached to the mounting frame before installing the frame in the instrument panel. The rear connector plate can be used to tie down the cable assemblies. Connect the shield grounds directly to the connector mounting plate.

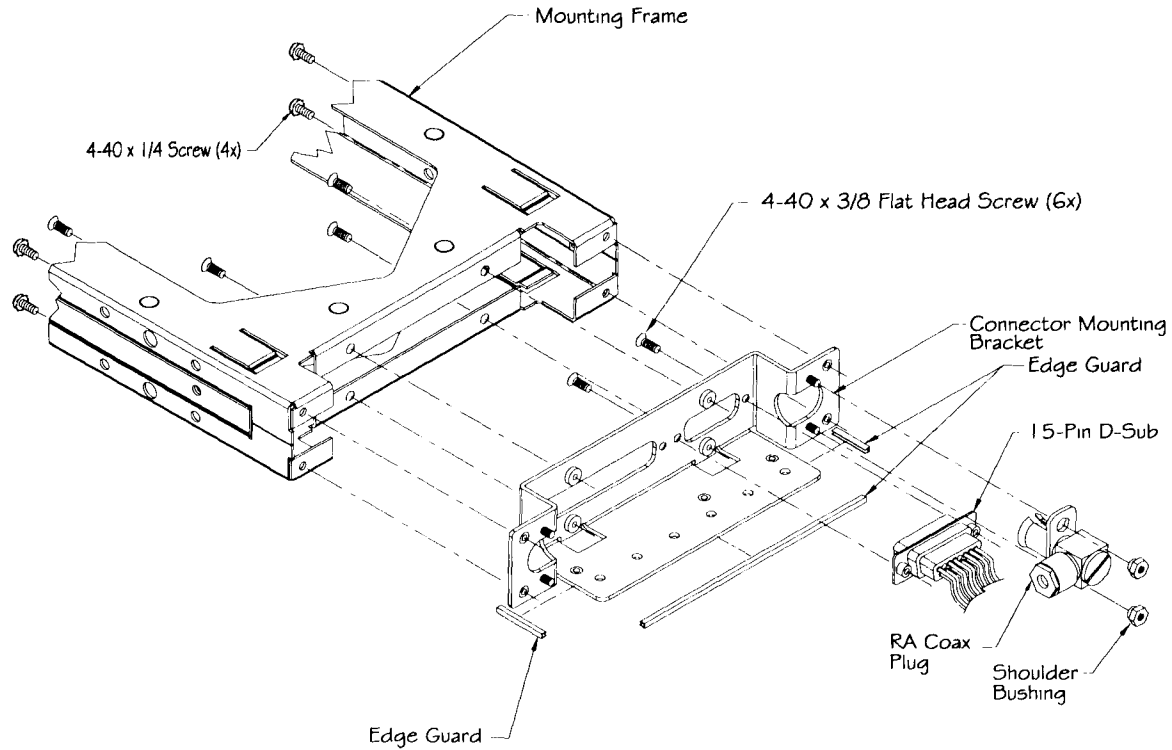

Figure 2 Mounting Frame Assembly

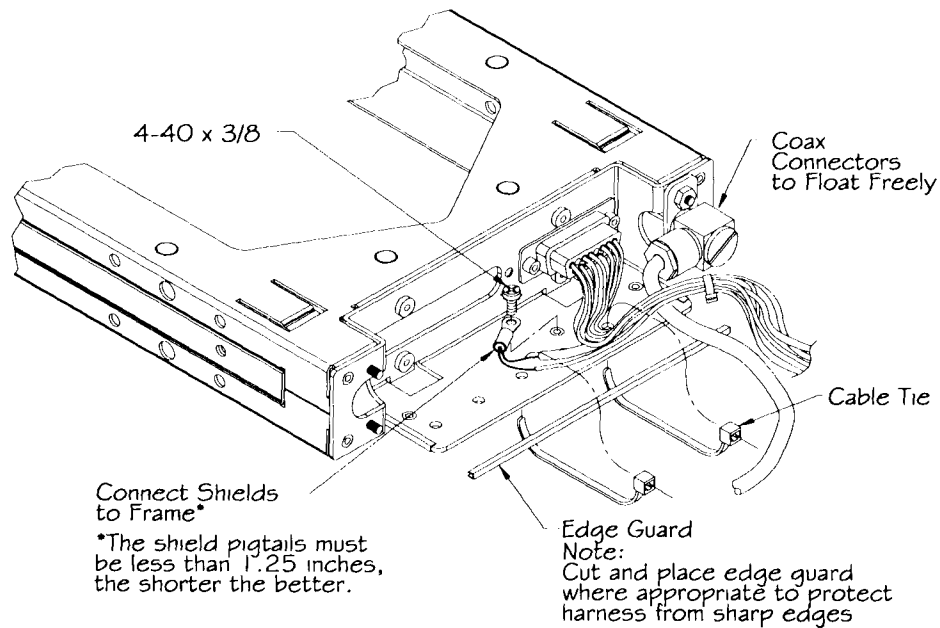

Figure 3 Cable Routing

Once the cable assemblies are complete and the connectors are attached to the mounting frame, install the mounting frame assembly in the instrument panel. Be sure to use low profile head screws so the unit will slide in and out freely. Attach the front of the mounting frame to the instrument panel. Use support brackets to attach the rear of the frame to the aircraft.

head screws so the unit will slide in and out freely. Attach the front of the mounting frame to the instrument panel. Use support brackets to attach the rear of the frame to the aircraft.

To install the unit in the mounting frame, make sure the cam lock is rotated so the rear part is up, then slide the unit into the frame and tighten with the 3/32 hex tool. The unit will be pulled into the frame by the cam lock and the connectors will fully engage.

To remove the unit from the mounting frame, use the hex tool and turn the tool CCW. The unit will be pushed out of the frame by the cam lock assembly. No special extraction tools are required.

ELECTRICAL CONNECTIONS

The SL40 installation kit includes a 15 pin dsub shell and crimp contacts. The crimp contacts are specified for 20 to 24 AWG wire. Make the crimp connections with a crimp tool as specified in the Special Tools Required section on page 4. All wires should be 20 to 24 AWG unless otherwise specified. A wiring diagram is included as Figure 5.

POWER

The SL40 is internally fused at 7 amps. A separate 5 amp (maximum) circuit breaker or fuse should be installed for downline overload or short circuit protection. Make the power connections to the SL40 using 20 awg wire.

Note: Circuits should be protected in accordance with guidelines in AC 43.13-1A, chapter 11, section 2, paragraph 429.

SPEAKER AND HEADPHONE OUTPUTS

Connect the speaker and headphones to the output pins on the rear connector.

MICROPHONE INPUTS

Microphone input connections should be made using a twisted pair shielded cable. Attach the signal ground to the mic ground pin on the rear connector and connect the shield to the rear connector plate.

TRANSMIT KEY INPUT

The TxKey input on the rear connector must be pulled low to ground to enable the transmitter. This input should be connected to a microphone or yoke mounted momentary push button switch.

INTERCOM SELECTOR SWITCH

The SL40 includes an intercom function that can be enabled by an external control switch. This is an optional connection.

When making connection for the intercom selection, connect the intercom selection input to a remote mounted normally open switch. A momentary toggle or alternate action switch can be used. Connect the other terminal of the switch to ground. The intercom function is enabled when the input is pulled low to ground.

SERIAL INTERFACE

The SL40 includes an RS232 serial port, which can be used for inputting frequency and function control commands and outputting transceiver status. This is an optional connection.

When making serial connections to the SL40, use a shielded three conductor cable. Make the RxD, TxD, and ground connections on the 15 pin connector. Connect the shield to the rear of the mounting frame on the connector plate.

The SL40 can be connected to the RS-232 serial data outputs on the 2001GPS (requires software version 5.1 or later), the SL50, SL60, GX50, GX55, GX60, or the 360 Map/GPS for receiving remote frequency information from the GPS navigation data base. Refer to the installation manuals for those units for connections and serial data output selections.

Complete serial interface specifications are included in Appendix E.

ANTENNA INSTALLATION AND CONNECTIONS

The SL40 requires a standard 50Ω vertically polarized antenna. Follow the antenna manufacturer's installation instructions for mounting the antenna.

The antenna should be mounted on a metal surface or a ground plane with a minimum area of 18 x 18 inches. The antenna should be mounted a minimum of 24 inches away from GPS antennas.

The comm antenna should also be mounted as far apart as practical from the ELT antenna, preferably one on top and the other on the bottom of the aircraft fuselage. Some ELTs have exhibited re-radiation problems generating harmonics that may interfere with GPS signals. This can happen when the comm (SL40 or any other comm) is transmitting on certain frequencies such as 121.15 or 121.175 MHz, which may cause the ELT output circuit to oscillate from the signal coming in on the ELT antenna coax.

The antenna coax cable should be made of RG-142B or a comparable quality 50Ω coax. Assembly instructions for the rear coax connector are included in Figure 4.

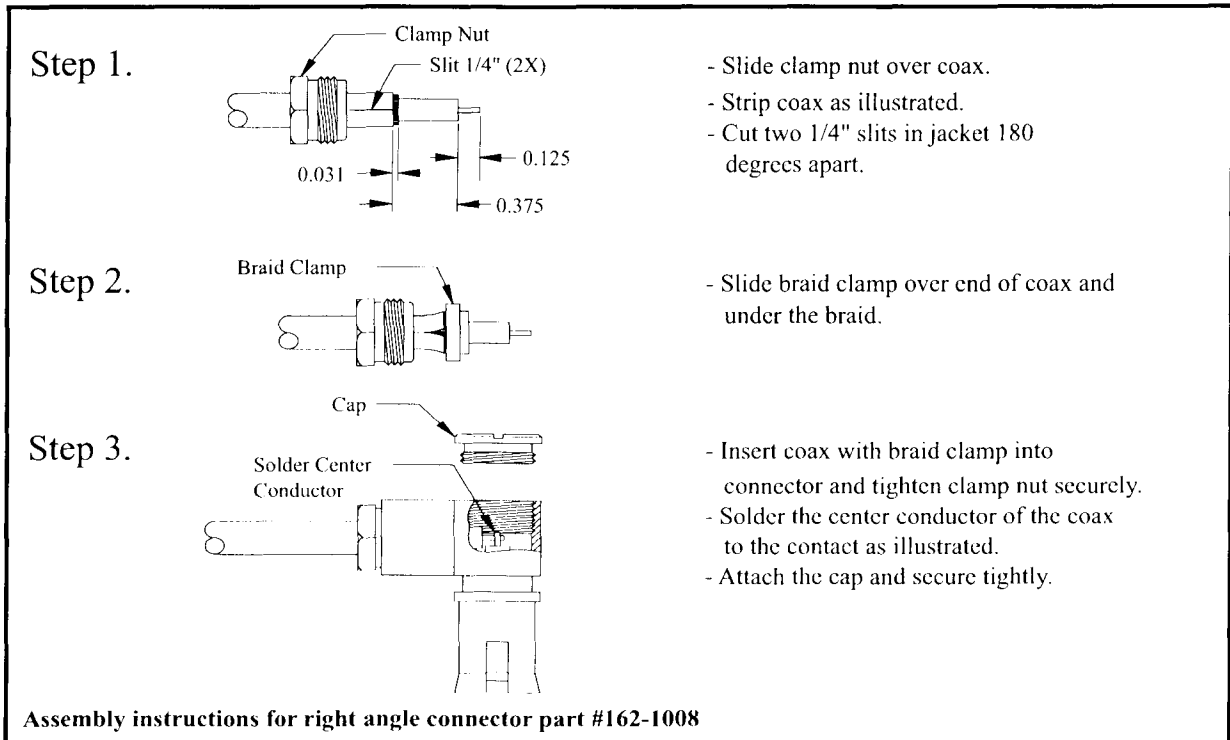
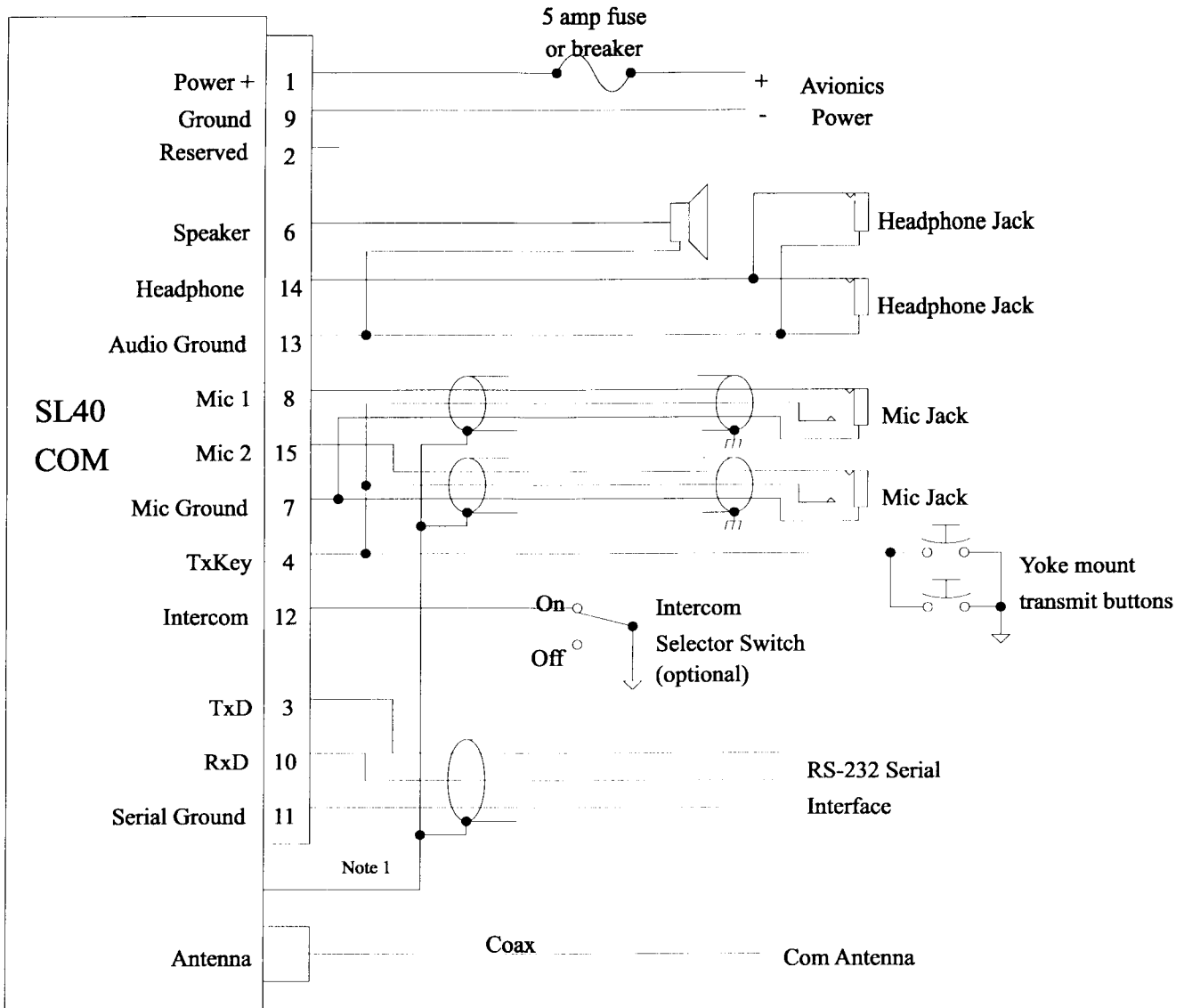
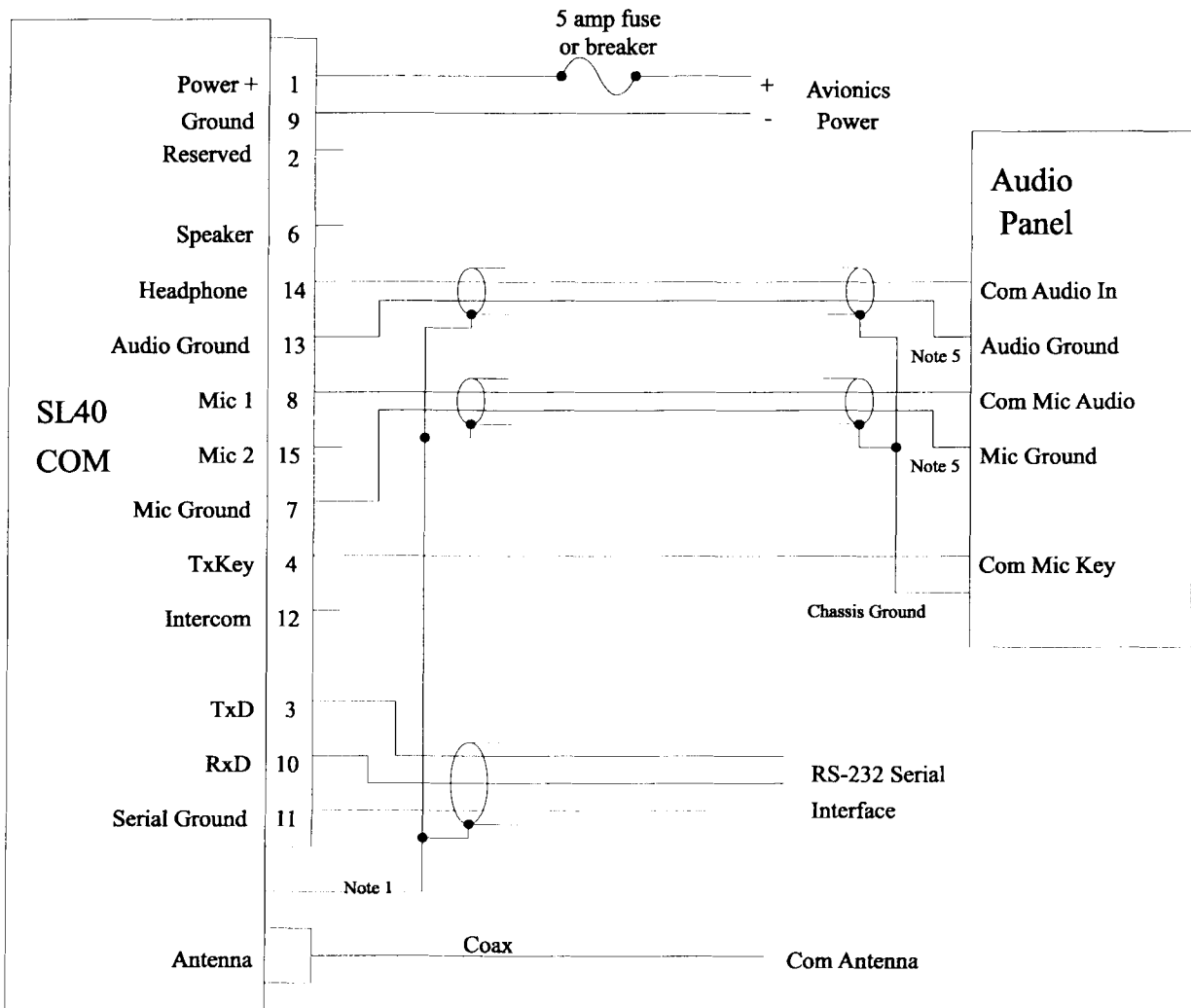

Figure 4 Coax Connector Assembly



- Notes:**
1. Connect cable shields to the rear of the mounting frame, with pigtails < 1.25 inches.
 2. Use shielded cable for the microphone connections.
 3. Use shielded cable for the RS-232 serial interface connections.
 4. Connect shields to chassis ground at both ends of cables.

Figure 5 SL40 Standalone Wiring Diagram



- Notes:**
1. Connect cable shields to the rear of the mounting frame, with pigtailed < 1.25 inches.
 2. Use shielded cable for the microphone connections.
 3. Use shielded cable for the RS-232 serial interface connections.
 4. Connect shields to chassis ground at both ends of cables.
 5. The audio ground and mic ground connections may use a common point at the audio panel.

Figure 6 SL40 Typical Audio Panel Connections

POST INSTALLATION CHECKOUT

Once the unit is installed, complete the checkout procedure to verify proper operation. Refer to the User's Guide for operating instructions.

Mounting / Wiring Check

Verify that all cables are properly secured and shields are connected to the rear of the mounting frame. Check the movement of the aircraft controls to verify that there is no interference.

Receiver / Transmitter Operation

Tune the unit to a local frequency and verify the receiver output produces a clear and understandable audio output. Verify the transmitter by contacting another station and getting a report of reliable communications.

Antenna Check

The antenna VSWR can be checked using an inline watt meter in the antenna coax using frequencies near both ends of the band. The VSWR should be < 2:1, and is not to exceed 3:1. A VSWR of 2:1 will cause a drop in output power of approximately 12%, and 3:1 causes approximately a 26% drop.

Interference Check

Check the SL40 while operating the other avionics and electrical systems on the aircraft to verify that no significant interference exists, and that the SL40 does not cause significant interference with other systems. Performance should be checked using low, high, and mid band frequencies. Repeat during the flight test for equipment that is not checked on the ground.

Sidetone Level Adjustment

The sidetone volume was preset at the factory to what should be an acceptable level. The level can be adjusted in the System Functions mode. To adjust the sidetone level:

1. Press and hold the MON button for about two seconds. This will access the System Functions mode.
2. Rotate the LARGE knob to display the SIDETONE LVL page.
3. Rotate the SMALL knob to change the level number. The range of the number is 000 to 255, with 128 producing one half of full rated output. A setting of 000 slaves the level to the Volume knob.
4. Press any key to exit the Setup Functions mode.
5. Select an appropriate frequency, key the transmitter, and talk into the microphone to check the level.

Receiver Squelch Adjustment

Adjustments to the receiver squelch level may be performed by using the RCVR SQELCH page in the Test Mode. Values may be adjusted between 25 and 100.

1. Press and hold the ⇔ and RCL keys while switching the unit on.
2. Turn the LARGE knob to the RCVR SQELCH page.
3. Press the ⇔ key to start selection (the number will flash).
4. Turn the SMALL knob to change the value. Press MEM to store the value.
5. Turn the unit off to exit the Test Mode.

Mic Level Adjustment

Those units with audio board p/n 415-7008-01, or later, have the ability to make adjustments to microphone sensitivity by using the MIC 1 LEVEL and MIC 2 LEVEL pages in the Test Mode.

1. Press and hold the ⇔ and RCL keys while switching the unit on.
2. Turn the LARGE knob to the MIC 1 LEVEL and MIC 2 LEVEL pages.
3. Press the ⇔ key to start selection (the number will flash).
4. Turn the SMALL knob to change the value. Press MEM to store the value.
5. Turn the unit off to exit the Test Mode.

Display Test

It is possible to perform a simple test to observe all segments of the display for a quick checkout of the display functions.

1. Press and hold the ⇔ and RCL keys while switching the unit on.
2. Turn the LARGE knob to the DISPLAY TEST page.
3. Press MEM to perform the test. A series of “#” symbols will advance across the display testing each LED.
4. Turn the unit off to exit the Test Mode.

Mic Squelch

Adjustments to the squelch levels for Mic1 and Mic2 are available in the System Functions mode. To adjust the Microphone Squelch level:

1. Press and hold the MON button for about two seconds. This will access the System Functions mode.
2. Rotate the LARGE knob to display the MIC1 OR MIC2 SQLCH pages.
3. Rotate the SMALL knob to change the level number. The range of the number is 000 to 127.
4. Press any key to exit the Setup Functions mode.
5. Select an appropriate frequency, key the transmitter, and talk into the microphone to check the level.

Transmit Mic

The Transmit Microphone page allows you to control which microphone is permitted to transmit. You may choose Mic 1, 2, or both. To adjust the Transmit Mic control:

1. Press and hold the MON button for about two seconds. This will access the System Functions mode.
2. Rotate the LARGE knob to display the TRANSMIT MIC page.
3. Rotate the SMALL knob to select MIC1, MIC2, or MIC1+MIC2.
4. Press any key to exit the Setup Functions mode.
5. Select an appropriate frequency, key the transmitter, and talk into the microphones to check for the intended operation.

Flight Test Check

A flight test is recommended as a final installation verification. The performance may be verified by contacting a ground station at a range of at least 50 nm while maintaining an appropriate altitude and over all normal flight attitudes. Performance should be checked using low, high, and mid band frequencies.

NOTES

SECTION 3 - SPECIFICATIONS

This section includes detailed electrical, physical, environmental, and performance specifications for the SL40.

ELECTRICAL

Input voltage.....	10 VDC to 40 VDC, reverse polarity protected
Input current	270 mA typical, 350 mA max. at 13.75 VDC, receive 140 mA typical, 900 mA max. at 27.5 VDC, receive 2.1A typical, 3.2A max. at 13.75 VDC, transmit 1.0 A typical, 1.4 A max. at 27.5 VDC, transmit Note: receive max. at full receive audio, transmit max. at 90% modulation at 1000Hz
Input power	4 watts typical, receive 28 watts typical, transmit
Internal fuse.....	7 amp fast blow, soldered in board
Power control connection.....	Pulled low to turn unit ON; floating (high) for unit OFF

PHYSICAL

Height	1.30 inches (3.30 cm)
Width.....	6.25 inches (15.88 cm)
Depth	11.452 inches (29.09 cm) behind panel, including mounting frame and connectors
Weight (with mounting frame).....	2.1 lb. (0.953 kg)

ENVIRONMENTAL

The SL40 unit is designed and tested to meet appropriate categories of RTCA/DO-160C. The Environmental Qualification Form is included in Appendix C.

Operating temperature.....	-20°C to +55°C
Storage temperature.....	-55°C to +85°C
Temperature variation	2°C per minute
Humidity.....	95% at 50°C for 6 hours (2 day cycle)
Maximum altitude	35,000 feet
Cooling.....	Not required

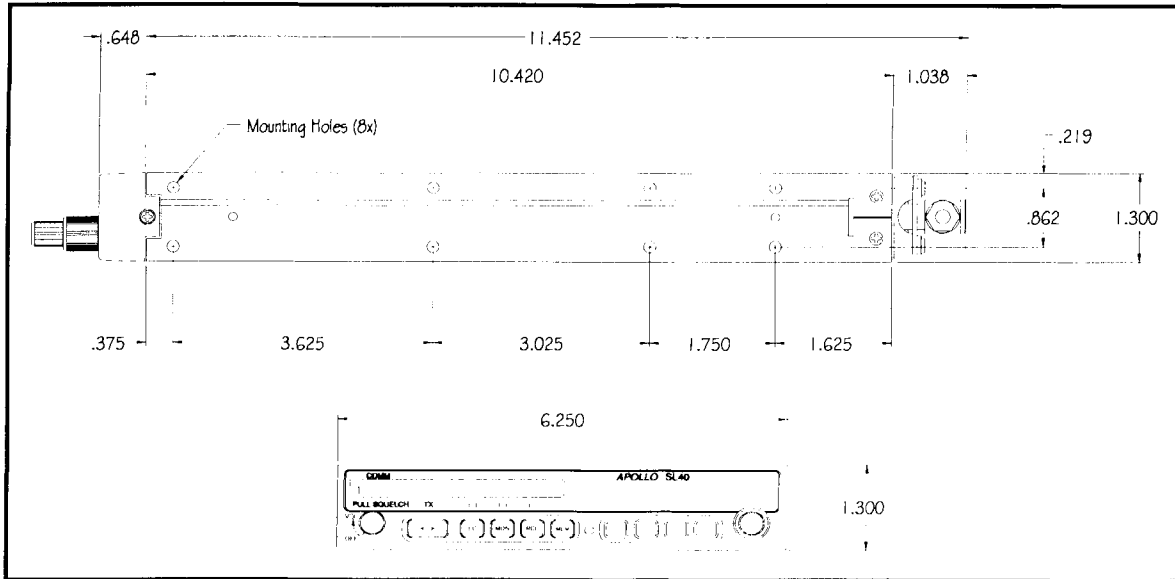

Figure 7 Unit Dimensions

RECEIVER PERFORMANCE

- Class.....D
- Frequency range.....118.000 to 136.975 MHz, 760 channels
- Sensitivity1 μ V (2 μ V hard) for 6 dB S+N/N with 30% modulation at 1000Hz
- Selectivity< 6 dB variation at \pm 7 kHz, > 60 dB at \pm 22 kHz
- Speaker audio output level.....12 watts into 4 Ω , 8 watts into 8 Ω
- Headphone audio output level280mW into 100 Ω , 120mW into 500 Ω
- Distortion< 5% at rated output at 1000Hz
- AGC characteristics< 3 dB variation in audio output from 5 μ V to 100mV input, 15% to 90% modulation
- Squelch controlAutomatic squelch with manual override

TRANSMITTER PERFORMANCE

- Class.....4
- Output power8 watts minimum carrier at >12VDC input, 6 watts minimum at 10VDC input (transmit is locked out below 9 volts input)
- Frequency range.....118.000 to 136.975 MHz, 760 channels
- Frequency tolerance..... \pm 15ppm from -20 $^{\circ}$ C to +70 $^{\circ}$ C

Microphone input	Two inputs, standard carbon or dynamic mic with integrated preamp providing minimum 70mv rms into 1000Ω load
Modulation capability	85% with 100mv to 1000mv rms microphone input at 1000 Hz
Audio frequency distortion.....	< 10% at 85% modulation at 350 to 2500 Hz
Audio frequency response.....	< 4db variation with 350 to 2500 Hz, 85% modulation
Carrier noise level	> 35 dB down
Siditone output.....	up to 280mW into 100Ω, 120mW into 500Ω
Duty cycle	100%
Stuck mic time-out	35 second time-out, reverts to receive

INTERCOM PERFORMANCE

Microphone input	Two inputs, standard carbon or dynamic mic with integrated preamp providing minimum 70mv rms into 1000Ω load
Headphone audio output level.....	280 mW into 100Ω, 120 mW into 500Ω
AGC characteristic	output varies < 3 dB with input of 100mv rms to 1000mv rms

CONTROL INPUTS

Transmit key.....	Input pulled low to ground to enable the transmitter
Intercom select	Input pulled low to ground to enable the intercom function

ANTENNA REQUIREMENTS

The SL40 requires an antenna meeting the following specifications.

Standard 50Ω vertically polarized antenna with a VSWR < 2.5:1.

SERIAL INTERFACE

RS-232.....	Defined in Appendix E - Serial Interface Specifications
-------------	---

REAR CONNECTOR PINOUT

Table 2 Connector Pinout			
Pin #	I/O	Connection	Function
1	I	Power +	main DC power input
2	I	Reserved	Do not connect
3	O	TxD	RS232 serial data output
4	I	TxKey	transmit enable key, pulled low to transmit
5	--	NC	Do not connect
6	O	Speaker	speaker terminal output
7	I	Mic ground	microphone input ground connection
8	I	Mic 1	microphone input #1
9	I	Power ground	main power ground input
10	I	RxD	RS232 serial data input
11	O	Serial ground	RS232 signal ground
12	I	Intercom select	intercom function select, pulled low to turn on the intercom function
13	O	Audio ground	speaker and headphone ground connection
14	O	Headphone	headphone terminal output
15	I	Mic 2	microphone input #2

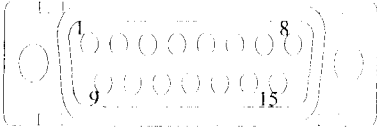

Viewed from rear of unit

SECTION 4 - LIMITATIONS

INSTALLATION

Installations are to be made in accordance with AC 20-67B or other appropriate FAA approved guidelines.

OPERATIONAL

An aircraft radio station license is required for transmitting. Please follow your local procedures.

Limitations

NOTES

APPENDIX A - TROUBLESHOOTING

This appendix provides information to assist troubleshooting if problems occur after completing the installation. Use Table 3 to assist in troubleshooting.

Table 3 Troubleshooting Guide		
Problem	Cause	Solution
The SL40 does not power on.	The unit is not getting power.	Check power connections, breakers, and main avionics switch.
The unit does not transmit.	The TxKey input is not being pulled low. A weather channel is selected. The input voltage is too low.	Check the TxKey (mic key) input, pulled low for transmit. Select a different frequency, the unit will not transmit on a weather channel. Increase input supply voltage to > 9 volts DC.
Mic Sensitivity varies	Mic Levels need adjustment	See the Mic Level Adjustment on page 13
The sidetone and intercom levels are too low or high.	Wrong type of headsets, or level needs adjustment.	See the Sidetone Level Adjustment on page 12.
The intercom doesn't function.	Control input not connected. No voice activation, or have to talk too loud.	The intercom select input must be pulled to ground to turn on the intercom function. Change the intercom squelch threshold using the setup function described in the user's manual.

CONTACTING THE FACTORY FOR ASSISTANCE

If the SL40 unit fails to operate despite troubleshooting efforts, contact the Garmin AT factory for assistance.

GARMIN International, Inc.
1200 East 151st Street
Olathe, KS 66062-3426
USA

Phone: (913) 397-8200
FAX: (913) 397 8282

<http://www.garmin.com>

Be prepared to offer the following information about the installation:

- Installation configuration (accessories, antenna, ...)
- Model number, part number with mod levels, and serial number
- Software version
- Description of problem
- Efforts made to isolate the problem

NOTES

APPENDIX B - PERIODIC MAINTENANCE

EQUIPMENT CALIBRATION

The SL40 design requires very few adjustments or calibration to be made. In fact, there are **no** internal manual adjustments.

REFERENCE OSCILLATOR

The reference oscillator frequency should be checked approximately every 3 to 5 years to ensure the units transmit frequency is within allowable tolerance.

The oscillator frequency can be checked by connecting the transmitter output through an appropriate load to a calibrated frequency counter. The transmit frequency should be within 15ppm of the selected channel frequency. Contact the Garmin AT, Inc. factory for instructions on adjusting the frequency if required.

CLEANING THE FRONT PANEL

The front bezel, keypad, and display can be cleaned with a soft cotton cloth dampened with clean water. **DO NOT** use any chemical cleaning agents. Care should be taken to avoid scratching the surface of the display.

NOTES

APPENDIX C - ENVIRONMENTAL QUALIFICATIONS

The SL40 has been tested to the following environmental categories per procedures defined in RTCA/DO-160C.

Environmental Qualification Form		
Nomenclature: SL40 Part No.: 430-6040-200 TSO No.: TSO-C37d, TSO-C38d, and TSO-C128 ETSO No.: ETSO-2C37e, ETSO-2C38, and ETSO-2C128.		Manufacturer: Garmin AT, Inc. 2345 Turner Road SE Salem, Oregon 97302
Conditions	Section	Description of Conducted Tests
Temperature and Altitude	4.0	Equipment tested to Category C1 with
In-flight Loss of Cooling	4.5.4	No cooling required
Altitude	4.6.1	Equipment tested to 35,000 feet
Overpressure	4.6.3	Equipment tested for overpressure
Temperature Variation	5.0	Equipment tested to Category C, 2°C/min
Humidity	6.0	Equipment tested to Category A, standard humidity environment
Operational Shocks and Crash Safety	7	Equipment tested for both operational and crash safety shocks. (Equipment operated normally after the crash safety shocks.)
Vibration	8.0	Equipment tested without shock mounts to Categories B, M, & N
Explosion Proofness	9.0	Equipment identified as Category X, no test required
Waterproofness	10.0	Equipment identified as Category X, no test required
Fluids Susceptibility	11.0	Equipment identified as Category X, no test required
Sand and Dust	12.0	Equipment identified as Category X, no test required
Fungus Resistance	13.0	Equipment identified as Category X, no test required
Salt Spray	14.0	Equipment identified as Category X, no test required
Magnetic Effect	15.0	Equipment is Class Z.
Power Input	16.0	Equipment tested to Categories A & B
Voltage Spike	17.0	Equipment tested to Category A
Audio Frequency Conducted Susceptibility - Power Inputs	18.0	Equipment tested to Categories A & B
Induced Signal Susceptibility	19.0	Equipment tested to Category Z.
Radio Frequency Susceptibility (Radiated and Conducted)	20	Equipment tested to Category V for conducted, Category U for radiated.
Emission of Radio Frequency Energy	21	Equipment tested to Category Z
Lightning Induced Transient Susceptibility	22.0	Equipment tested to Categories A3 and B2. RS-232 input/output tested to A3 and B1.
Lightning Direct Effects	23.0	Equipment identified as Category X, no test required
Icing	24.0	Equipment identified as Category X, no test required
Remarks:		

NOTES

APPENDIX E - SERIAL INTERFACE SPECIFICATIONS

This appendix includes the interface specifications for the RS-232 serial port. The RS-232 port can be used to input active and standby frequencies, and is used to input frequencies from a remote source, such as the SL50 and 2001GPS. The interface format conforms to NMEA 0183 message format specifications.

The format of the RS-232 serial port is as follows:

```
Baud rate ..... 9600
Data bits ..... 8
Stop bits..... 1
Parity ..... none
```

The data format is as follows:

```
$PMRRC<msg_id><msg_data><chksum><cr>
```

The checksum is computed by an 8 bit addition of the msg_id and msg_data characters, ignoring carry if any. The resulting 8 bit checksum is converted to two ascii characters by taking the upper and lower nibbles, adding 30h to each, and placing the most significant character first in the data message.

RS-232 INPUTS

SET ACTIVE FREQUENCY

Message Format

```
$PMRRC00mka<chksum><cr>
```

00..... message id

mk..... active frequency:

m = desired frequency in MHz in hexadecimal, where m = desired frequency - 30h, with desired frequency in range of 118 to 136 MHz, or 162 MHz.

k = desired frequency in kHz where k = (desired frequency / 25 kHz) + 30h, with desired frequency in range of 000 to 975 kHz in 25 kHz steps, or 0 to 39.

a..... transceiver function:

N = normal receive operation

M = enable monitor function

0 = no change

Example Message

```
$PMRRC00G4N29<cr>
```

Set the active frequency to 119.100MHz, normal receive mode. "G" = 119d - 30h = 77h - 30h = 47h, or an ascii "G"; "4" = 100 kHz/25 kHz + 30h = 4 + 30h = 34h, or an ascii "4."

SET STANDBY FREQUENCY

Message Format

\$PMRRC01mka<chksum><cr>

01message id

mkstandby frequency:

m = desired frequency in MHz in hexadecimal, where m = desired frequency - 30h, with desired frequency in range of 118 to 136 MHz, or 162 MHz.

k = desired frequency in kHz where k = (desired frequency / 25 kHz) + 30h, with desired frequency in range of 000 to 975 kHz in 25 kHz steps, or 0 to 39.

a.....transceiver function:

N = normal receive operation

M = enable monitor function

0 = no change

Example Message

\$PMRRC01LFM40<cr>

Set the standby frequency to 124.550 MHz, monitor function selected

REMOTE IDENT INPUT

This message is used to input a new ident, and reset the remote frequency input pointer.

Message Format

\$PMRRC04tiii<chksum><cr>

04message id

t.....list type, input 1

iii.....ident, four character ascii

Example Message

\$PMRRC041SLE<space>99<cr>

Set the remote frequency ident to "SLE."

REMOTE FREQUENCY LIST INPUT

This message is used to input frequencies for the remote recall function. Up to 10 frequencies are accepted.

Message Format

\$PMRRC05tfmk<chksum><cr>

05message id

t.....list type, input 1

f.....frequency type:

0 = TWR, tower frequency

1 = GND, ground frequency

2 = ATS, for ATIS

3 = ATF, air traffic frequency

4 = APP, for approach

5 = ARR, for arrival

8 = CTF, common traffic advisory frequency

9 = DEP, departure

: (3Ah) = FSS, flight service station

; (3Bh) = RFS, for remote flight service station

< (3Ch) = UNI, for unicom

= (3Dh) = MF, mandatory frequency

6 = AWS, automatic weather station > (3Eh) = not defined, do not use
 7 = CLR, clearance/delivery ? (3Fh) = undefined, for other frequency types

mk..... frequency:

m = desired frequency in MHz in hexadecimal, where m = desired frequency - 30h , with desired frequency in range of 118 to 136 MHz, or 162 MHz.

k = desired frequency in kHz where k = (desired frequency / 25 kHz) + 30h, with desired frequency in range of 000 to 975 kHz in 25 kHz steps, or 0 to 39.

Example Message

```
$PMRRC0511IT64<cr>
```

Input a ground frequency type, 121.900 MHz.

REQUEST OUTPUT MESSAGE

This message is used to request data output messages.

Message Format

```
$PMRRC06iidda<chksum><cr>
```

06..... message id

ii requested message ident:

03 = software version message

dd..... set to 00

a set to 0

Example Message

```
$PMRRC060300059<cr>
```

This message requests the software version message to be output.

RS-232 OUTPUTS

TRANSCEIVER STATUS

This message is used to output the current transceiver frequencies and status.

Message Format

```
$PMRRC01mkmkas<chksum><cr>
```

01..... message id

mk..... active frequency (first mk):

m = frequency in MHz in hexadecimal, where m = frequency - 30h , with frequency in range of 118 to 136 MHz, or 162 MHz.

k = frequency in kHz where k = (frequency / 25 kHz) + 30h, with frequency in range of 000 to 975 kHz in 25 kHz steps, or 0 to 39.

mk..... standby frequency (second mk):

m = frequency in MHz in hexadecimal, where m = frequency - 30h , with frequency in range of 118 to 136 MHz, or 162 MHz.

k = frequency in kHz where k = (frequency / 25 kHz) + 30h, with frequency in range of 000 to 975 kHz in 25 kHz steps, or 0 to 39.

a transceiver status:

R = normal receive
M = monitor selected
T = transmit enabled
S = stuck mic

s.....squelch test setting:

0 = automatic
1 = test selected

Example Message

\$PMRRC01G4LFR0F0<cr>

The active frequency is 119.100 MHz, the standby frequency is 124.550 MHz, normal receive function, automatic squelch selected.

This message is output once/second.

SOFTWARE VERSION

This message is used to output the com software version.

Message Format

\$PMRRC03vvvv<chksum><cr>

03message id

vvvv ...software version

Example Message

\$PMRRC03010024<cr>

The software version is 01.00.

This message is output once at power up and by request.

Declaration of Conformity

Manufacturer's name: Garmin AT, Inc.
Manufacturer's address: 2345 Turner Rd. SE
Salem, Oregon, 97302 USA

declares that the following product:

Type of equipment: VHF Comm transceiver for aircraft
Product name: SL40 Comm
Part number: 430-6040-2xx

conforms to the following Directives and Standards:

Application of Council Directives: 89/336/EEC, 93/68/EEC
Standards: EN50081-1, EN50082-1

Quality Department
Garmin AT, Inc.

GARMIN  TM