

ENDURANCE BUS LOAD ANALYSIS

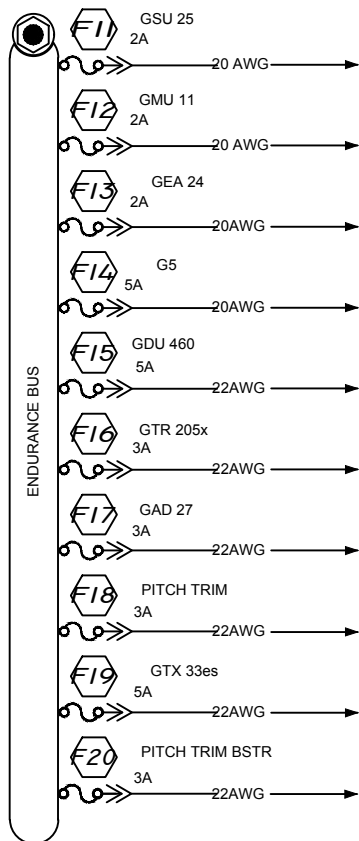

APPLIANCE	PRE-FLIGHT	TAXI	TAKEOFF CLIMB	CRUISE	APPRCH TO LDG	EMERG
GAD 25 (P2.1)	0.2	0.2	0.2	0.2	0.2	0.2
GMU 11 (P2.2)	0.1	0.1	0.1	0.1	0.1	0.1
GEA 24 (P2.3)	0.5	0.5	0.5	0.5	0.5	0.5
G5 (P2.4)	0.2	0.2	0.2	0.2	0.2	0.2
GDU 460 (P2.5)	2.0	2.0	2.0	2.0	2.0	2.0
GTR 205x (P2.6)	0.65 max 3.35	0.65 max 3.35	0.65 max 3.35	0.65 max 3.35	0.65 max 3.35	0.65 max 3.35
GAD 27 (P2.7)	0.2	0.2	0.2	0.2	0.2	0.2
PITCH TRIM (P2.8)	0.2	0.2	0.2	0.2	0.2	0.2
GTX 33es (P2.9)	1.6	1.6	3.1	3.1	3.1	1.6
PITCH TRIM (intermitent) (P3.0)	1.2 5.2	1.2 5.2	1.2 5.2	1.2 5.2	1.2 5.2	1.2 5.2
TOTALS	5.85 8.55 xt 11.05 Trim	5.85 8.55 xt 11.05 Trim	5.85 8.55 xt 11.05 Trim	5.85 8.55 xt 11.05 Trim	5.85 8.55 xt 11.05 Trim	5.85 8.55 xt 11.05 Trim

TITLE	PAGE
ESSENTIAL BUS & LOAD ANALYSIS	